

ARO®

Automatic Machining Tools

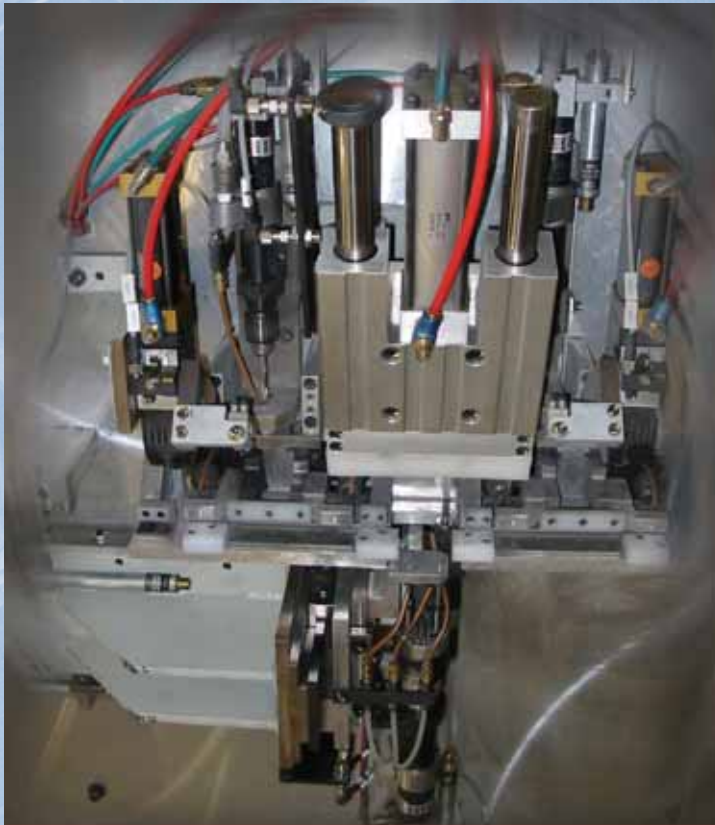

PROBLEM SOLVERS WORKING FOR YOU

DOBCO
EQUIPMENT LTD

Ontario's Largest
Pneumatic & Hydraulic Tool Distributor

1-2430 Lucknow Drive, Mississauga, Ontario L5S 1V3. Tel: 905-672-5557 Fax: 905-672-5559
Email: sales@dobcoeqp.com www.dobcoeqp.com

ARO®
IR Ingersoll-Rand®



For accuracy and performance at the cutting edge, ARO Automatic Machining Tools are the answer to today's needs and tomorrow's unforeseen challenges.





Numerical Model Index2

Tool Selection4

ARO Automatic Machining Tools5

Electric/Pneumatic Self-Feed Drills6-11

Series 34A Electra-Feed: 3/8" (9.5 mm) Capacity7

Series 54C & 74B Electra-Feed: 1/2" (12.7 mm) Capacity8-9

Series 34A, 54C & 74B Spindle Accessories10-11

Pneumatic Self-Feed Drills12-19

Bant-a-Matic Series: 3/16" (4.8 mm) Capacity12-13

Par-a-Matic Series: 5/16" (7.9 mm) Capacity12-13

Super Par-a-Matic Series: 1/2" (12.7 mm) Capacity12-13

Twin Drills: 1/8" to 3/8" (3.2 to 9.5 mm) Capacity14-15

Offset Drills: 3/16" (4.8 mm) Capacity16

Peck-Feed Drills: 5/16" (7.9 mm) Capacity17

High-Thrust 8670 Series: 5/8" (15.9 mm) Capacity18-19

Pneumatic-Self Feed & Lead Screw Tappers20-23

Bant-a-Matic Series: No. 0 to 1/4" (M1.6 to M6) Capacity20-21

Par-a-Matic Series: No. 0 to 1/2" (M1.6 to M12) Capacity20-21

2200 Series Lead Screw: No. 0 to 1/2" (M1.6 to M12) Capacity22-23

Spindle Accessories24-28

Drill Chucks, Taper Adapters, Tap Chucks24

Collets25

Twin Drill Head Attachments26-27

Twin Drill Collets28

Control Accessories29-38

Mounting Accessories.....39-49

CAD Drawings50

Tool Dimensional Data51-61

Service Kits62

Notes.....64

Contact Information65



MODEL	DESCRIPTION	PAGE
FE034A-()A-A	Series 34 Electra-Feed Drill	7
FE054C-()(-)A	Series 54 Electra-Feed Drill	8
FE074B-()(-)A	Series 74 Electra-Feed Drill	9
8245-B8-()	Bant-A-Matic, Valve-In-Head Drill	12
8245-B30-()	Bant-A-Matic, Valve-In-Head Drill	12
8245-B45-()	Bant-A-Matic, Valve-In-Head Drill	12
8245-101-()	Bant-A-Matic, Valve-In-Head Drill	12
8245-203-()	Bant-A-Matic, Valve-In-Head Drill	12
8246-D5-2	Bant-A-Matic, Clutch-Type Tapper	20
8246-D8-2	Bant-A-Matic, Clutch-Type Tapper	20
8248-B8-()	Bant-A-Matic, Twin Drill	14
8248-B30-()	Bant-A-Matic, Twin Drill	14
8248-B45-()	Bant-A-Matic, Twin Drill	14
8255-A5-()	Par-A-Matic, Valve-In-Head Drill	12
8255-A8-()	Par-A-Matic, Valve-In-Head Drill	12
8255-A14-()	Par-A-Matic, Valve-In-Head Drill	12
8255-A21-()	Par-A-Matic, Valve-In-Head Drill	12
8255-A28-()	Par-A-Matic, Valve-In-Head Drill	12
8255-A50-()	Par-A-Matic, Valve-In-Head Drill	12
8255-101-()	Par-A-Matic, Valve-In-Head Drill	12
8255-172-()	Par-A-Matic, Valve-In-Head Drill	12
8256-C5-2	Par-A-Matic, Clutch-Type Tapper	20
8256-C8-2	Par-A-Matic, Clutch-Type Tapper	20
8256-C14-2	Par-A-Matic, Clutch-Type Tapper	20
8257-A5-2	Par-A-Matic, Jaw-Type Tapper	20
8257-A8-2	Par-A-Matic, Jaw-Type Tapper	20
8257-A14-2	Par-A-Matic, Jaw-Type Tapper	20
8258-C5-()	Par-A-Matic, Twin Drill	14
8258-C8-()	Par-A-Matic, Twin Drill	14
8258-C14-()	Par-A-Matic, Twin Drill	14
8258-C21-()	Par-A-Matic, Twin Drill	14
8258-C28-()	Par-A-Matic, Twin Drill	14
8258-C50-()	Par-A-Matic, Twin Drill	14
8265-3-()	Super Par-A-Matic, Valve-In-Head Drill	12
8265-6-()	Super Par-A-Matic, Valve-In-Head Drill	12
8265-12-()	Super Par-A-Matic, Valve-In-Head Drill	12
8265-25-()	Super Par-A-Matic, Valve-In-Head Drill	12
8265-46-()	Super Par-A-Matic, Valve-In-Head Drill	12
8265-101-()	Super Par-A-Matic, Valve-In-Head Drill	12
8265-171-()	Super Par-A-Matic, Valve-In-Head Drill	12
8266-A7-()	Par-A-Matic, Offset Drill	16
8266-A12-()	Par-A-Matic, Offset Drill	16
8266-A17-()	Par-A-Matic, Offset Drill	16
8266-A23-()	Par-A-Matic, Offset Drill	16
8268-A3-()	Super Par-A-Matic Twin Drill	14
8268-A6-()	Super Par-A-Matic Twin Drill	14



MODEL	DESCRIPTION	PAGE
8268-A12-()	Super Par-A-Matic Twin Drill	14
8268-A25-()	Super Par-A-Matic Twin Drill	14
8268-A46-()	Super Par-A-Matic Twin Drill	14
8345-B8-()	Bant-A-Matic Thru-Head Drill	12
8345-B30-()	Bant-A Matic Thru-Head Drill	12
8345-B45-()	Bant-A Matic Thru-Head Drill	12
8345-203-()	Bant-A-Matic Thru-Head Drill	12
8355-A5-()	Par-A-Matic Thru-Head Drill	12
8355-A8-()	Par-A-Matic Thru-Head Drill	12
8355-A14-()	Par-A-Matic Thru-Head Drill	12
8355-A21-()	Par-A-Matic Thru-Head Drill	12
8355-A28-()	Par-A-Matic Thru-Head Drill	12
8355-A50-()	Par-A-Matic Thru-Head Drill	12
8355-171-()	Par-A-Matic Thru-Head Drill	12
8360-A5-3	Par-A-Matic Peck Drill	17
8360-A8-3	Par-A-Matic Peck Drill	17
8360-A14-3	Par-A-Matic Peck Drill	17
8360-A21-3	Par-A-Matic Peck Drill	17
8360-A28-3	Par-A-Matic Peck Drill	17
8360-A50-3	Par-A-Matic Peck Drill	17
8360-171-3	Par-A-Matic Peck Drill	17
8655-B()-()	Lead Screw Tapper	22
8656-B()-()	Lead Screw Tapper	22
8657-B()-()	Lead Screw Tapper	22
8658-B()-()	Lead Screw Tapper	22
8659-B()-()	Lead Screw Tapper	22
8670-4-3	Hi-Thrust Self-Feed Drill	18
8670-8-3	Hi-Thrust Self-Feed Drill	18
8670-13-3	Hi-Thrust Self-Feed Drill	18
8670-28-3	Hi-Thrust Self-Feed Drill	18
8670-47-3	Hi-Thrust Self-Feed Drill	18

SELF-FEED TOOL PERFORMANCE

TOOL SERIES	*MOTOR H.P.	*THRUST IN POUNDS	*AIR CONSUMPTION IN CUBIC FEET, AT WORKING SPEED	
			TYP. 6 SEC. CYCLE	ONE MIN. OPERATION
Bant-A-Matic 8245, 8246, 8248	1/4	90	1.5	15.0
Series 34A, Electra-feed	1/3	330	N/A	0.14 per cycle
Par-A-Matic 8255, 8256, 8258, 8266	1/2	170	2.3	23.0
Series 54C, Electra-feed	1/2	330	N/A	0.14 per cycle
Super Par-A-Matic 8265, 8268	3/4	250	2.9	29.0
Series 74B, Electra-feed	3/4	330	N/A	0.14 per cycle
Hi-Thrust 8670	1-1/4	500	5.0	50.0
Lead Screw Tapper, All	5/8	**	3.0	30.0

*At 90 PSI at tool inlet while operating **Positive feed mechanism - no piston thrust

SELF-FEED DRILL SELECTION GUIDE

HOW TO USE CHART . . . The selection chart below provides model recommendations based on factors of textbook speeds, actual drill test results, and judgements based on available power and thrust. It should be used as a guide only in selecting the model or models best suited to meet the general machining requirements of these materials. Proper selection of a feed tool for a specific application, however, must also take into account the density and hardness of the material to be drilled, the type of drill bit used, the cutting lubricant or coolant used, the production cycle desired, tool, life, and the amount of compressed air available.

Those models in italics are generally considered the more appropriate selections, but where more than one model is given the more powerful tool will do the job faster. Therefore, the best tool for the job will depend upon the desired production rate and the amount of available compressed air.

DRILL DIA.	ALUMINUM (2024-T4)		BRASS (SAE 72)		STEEL (SAE 1213)		WOOD, MEDIUM or FRP	
	Single Spindle	Twin Drill	Single Spindle	Twin Drill	Single Spindle	Twin Drill	Single Spindle	Twin Drill
1/16" (1.59 mm)	8245-203		8245-203			8258-C50		
	8255-101	8258-C50	8245-101	8258-C50	8245-B45	8248-B45	8245-203	8258-C50
1/8" (3.17 mm)	8245-B45	<i>8258-C50</i>	8245-B45	8258-C50	8245-B30	8258-C28	8245-101	8258-C50
	<i>8255-101</i>	8268-A46	<i>8255-101</i>	8268-A46	8245-A50	8268-A25	8245-B45	8268-A46
3/16" (4.76 mm)	8245-B30	8258-C28	8245-B30	8258-C28	<i>8255-A28</i>	<i>8268-A25</i>	8245-B30	8258-C28
	<i>8255-A50</i>	8268-A46	<i>8255-A50</i>	8268-A46	8265-25	8268-A12	<i>8255-A50</i>	8268-A25
1/4" (6.35 mm)	8245-B30	8258-C14	8245-B8	8258-C14	8255-A14	8258-C5	8245-B30	8258-C14
	<i>8255-A28</i>	8268-A46	<i>8255-A28</i>	8268-A46	<i>8265-25</i>	<i>8268-A12</i>	<i>8255-A28</i>	8268-A25
5/16" (7.92 mm)	8255-A14	8268-A25	8255-A28	8268-A25	8255-A5	8268-A12	8245-B8	8268-A25
	<i>8265-25</i>	8268-A12	<i>8265-25</i>	8268-A12	<i>8265-12</i>	8268-A6	<i>8255-A21</i>	8268-A25
3/8" (9.52 mm)	8265-12	8268-A12	8255-A14		8265-6	8268-A6	8255-A8	8258-A12
	8670-47	8268-A6	<i>8265-12</i>	8268-A12	8670-13	8268-A3	<i>8265-25</i>	8268-A25
7/16" (11.10 mm)	8265-12		8265-12		8265-6		8265-25	
	8670-47		8670-47		8670-13			
1/2" (12.70 mm)	8265-12		8265-12		8265-3		8265-12	
	8670-47		8670-28		8670-8		8670-47	
9/16" (14.27 mm)	8265-6		8265-6				8265-12	
	8670-28		8670-28		8670-8		8670-28	
5/8" (15.87 mm)	8265-3		8265-3		8265-3		8265-6	
	8670-13		8670-13		8670-4		8670-28	
11/16" (17.45 mm)							8265-3	
	8670-8		8670-8		8670-4		8670-13	
3/4" (19.05 mm)	8670-8		8670-4		8670-4		8670-8	



PRECISION AND VERSATILITY AT THE CUTTING EDGE

Today's fast paced and increasingly complex manufacturing environment demands versatile and affordable tools. Tools that are precise and reliable. Tools that are easy to use and simple to maintain, and most of all, able to evolve if and when production needs change. ARO automatic machining tools bring these qualities and more to your secondary machining operations.

Designed with extensive input from customers throughout industry, this tool line offers the most efficient and flexible tools for drilling, reaming, counter-sinking, counterdrilling and tapping requirements in most metals and non-metals. Whether your application is in plastic molding, metal die casting, or woodworking, ARO pneumatic and electric/pneumatic self-feed drills and lead screw tappers deliver highly effective and economical solutions to thousands of machining challenges.



Depending upon your process requirements and plant power sources, you can choose from electric/pneumatic or pneumatic self-feed drills, pneumatic self-feed and lead screw tappers, plus a wide range of spindle, control, and mounting accessories. All provide exceptional precision and versatility. For example, on one foundation for the new series 34 Electra-Feed Drill you can select from among 20 rapid-change speeds and 10 versatile spindle accessories to design a custom tool. Should your needs change, you can transform the tool with minimal additional investment - simply alter the speed via a new pulley set or switch your spindle accessory to address a new application.

The remarkable flexibility of Series 34, 54, and 74 models is surpassed only by their precision. Our spindle with pre-loaded bearing support offers accurate targeting, longevity, and runout of .001 T.I.R., or less. And built-in dwell control holds repeatable depth to within .002 inches. Electric spindle power is ideal for plants with a limited supply of compressed air, or for operations seeking to supplement existing pneumatic tools.

This catalog is the perfect starting point and your ARO distributor or representative will be happy to provide expert consultation to help you meet your business objectives.

- SERIES 34A 1/3 HP 5/16 CAPACITY STEEL
- SERIES 54C 1/2 HP 3/8 CAPACITY STEEL
- SERIES 74B 3/4 HP 1/2 CAPACITY STEEL

CUSTOMER-DRIVEN DESIGN FOR VERSATILITY AND EASY MAINTENANCE

ARO's Series 34, 54 and 74 models are highly flexible and extremely versatile, offering simple design innovations that put them ahead of other products in their class:

- An extensive selection of tapping heads, drill chucks, and collets that can be interchanged as applications demand.
- 20 spindle speeds for optimum performance, driven by an easy-to-access pulley system that can be changed quickly and easily to accommodate new diameters or materials.
- Compact size (24 inches) and modest weight (30 lbs.) for flexibility in use and mounting, allowing a maximum number of simultaneous secondary operations.
- A simple, customer-driven design that includes fewer parts than competitive tools - with less-frequent, lower-cost maintenance.
- A central module for three remote control options - electronic (24V DC), electric (115V AC), and pneumatic allows for easier machine diagnostics.
- Manual controls for feed and retract that remain operational for setup while using remote controls.
- Standard frame motors with dual voltage capabilities (230/460V AC).





RELIABLE AND PRECISE PERFORMANCE FOR CONSISTENT RESULTS

Each unique feature of the ARO Series 34, 54 and 74 Electra-Feed Drill supports unsurpassed performance accuracy:

- A precision spindle with pre-loaded bearing support for accurate targeting, longevity, and .001 t.i.r. runout, or less.
- Built-in dwell control that holds repeatable depth within .002 inches.
- Individually adjustable feed rate control for advance and retract.
- The longest usable tool stroke length (adjustable to 110 mm [4.33 inches]) available in such a compact tool.
- Variable thrust from 150 to 330 lbs. for proper penetration power and rate.
- A heavy duty, ball-bearing supported drive train that is fully sealed and prelubed.
- Air and electric I/O's for control and feedback.

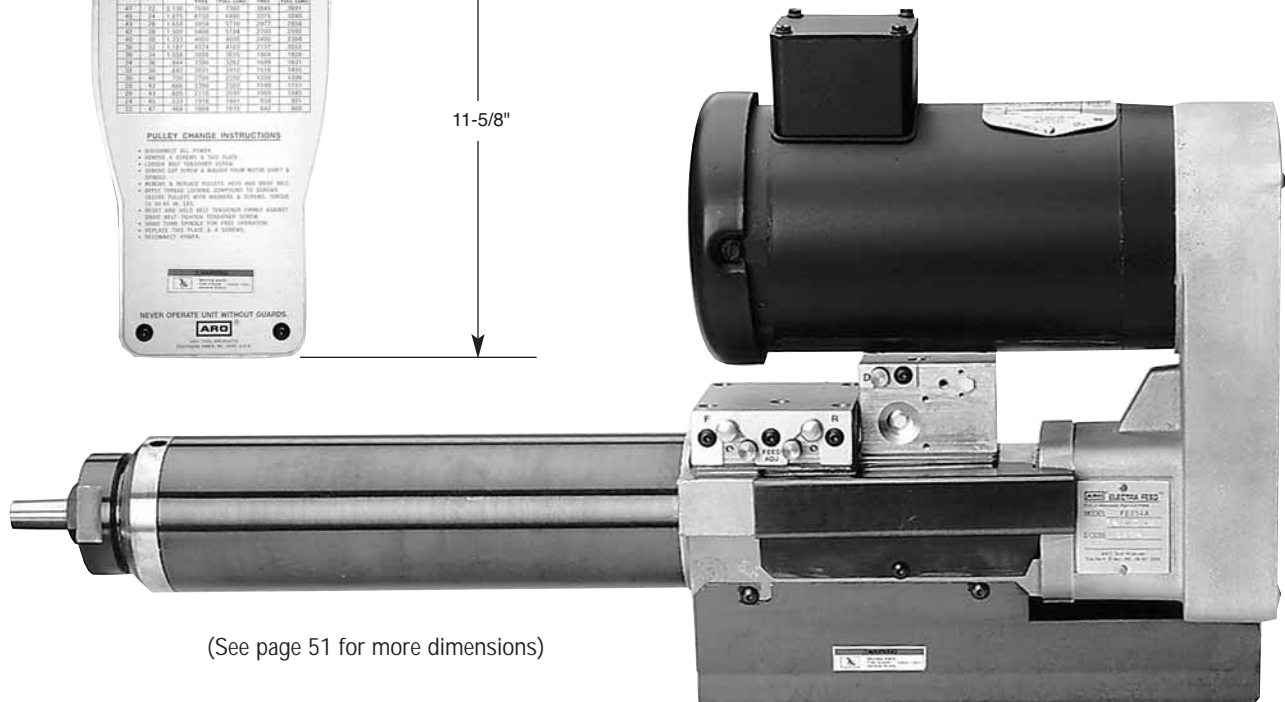
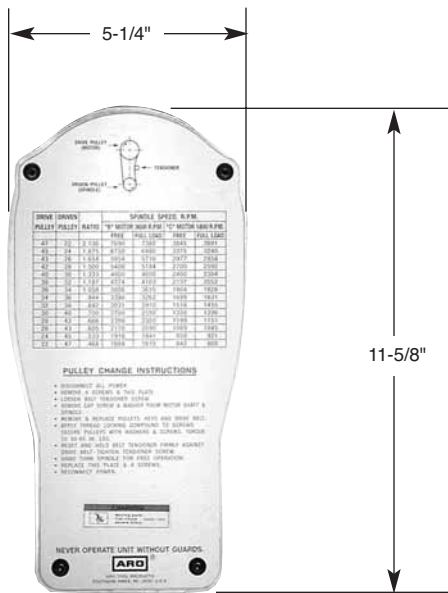
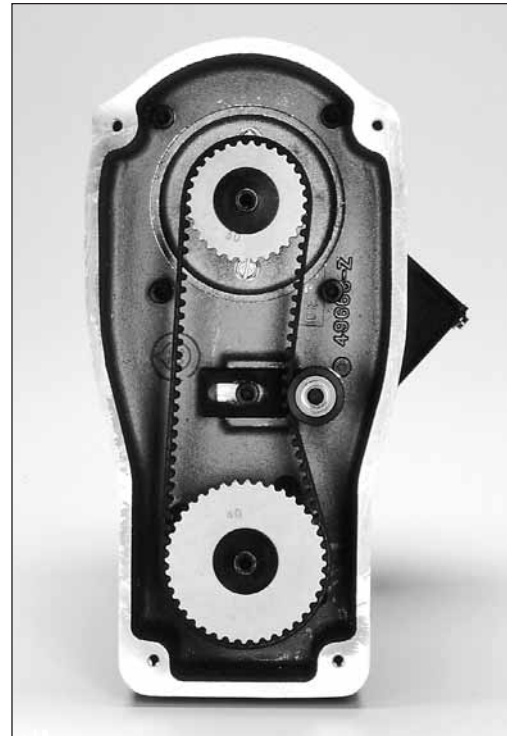

(See page 51 for more dimensions)

Electric/Pneumatic Self-Feed Drills



Made in the U.S.A. to the Following Specifications: F E 0 3 4 A - 7 7 B - A
 Example of product identification

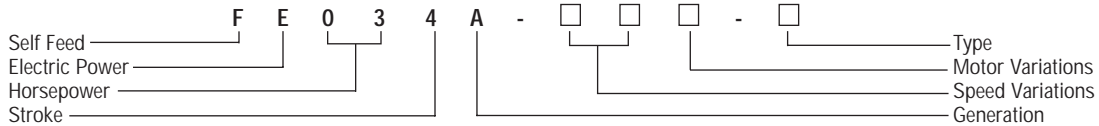

Model Number FE034A-()-A	Free Speed, R.P.M.	Load Speed Peak H.P. R.P.M.	Torque, Peak H.P. LB.FT.	Stainless 300 Series	Nominal Drilling Capacities Steel S.A.E. 1213	Aluminum 2024-T4	Med. Wood or F.R.P.
FE034A-77B-A	7690	7013	0.23	.018/.020	.036/.040	.070/.093	.078/.096
FE034A-67B-A	6750	6155	0.26	.020/.026	.040/.046	.093/.101	.096/.110
FE034A-59B-A	5954	5486	0.30	.026/.029	.046/.052	.101/.116	.110/.125
FE034A-54B-A	5400	4977	0.33	.029/.032	.052/.059	.116/.136	.125/.140
FE034A-48B-A	4800	4470	0.38	.032/.037	.059/.063	.136/.147	.140/.156
FE034A-43B-A	4274	3979	0.42	.037/.041	.063/.073	.147/.166	.156/.187
FE034A-38B-A	3808	3582	0.47	.041/.046	.073/.082	.166/.187	.187/.209
FE034A-34B-A	3398	3197	0.53	.046/.052	.082/.093	.187/.201	.209/.234
FE034A-30B-A	3030	2851	0.60	.052/.059	.093/.104	.201/.221	.234/.265
FE034A-27B-A	2700	2566	0.67	.059/.067	.104/.116	.221/.234	.265/.281
FE034A-24B-A	2400	2279	0.75	.067/.073	.116/.128	.234/.265	.281/.312
FE034A-22B-A	2178	2070	0.83	.073/.081	.128/.147	.265/.281	.312/.343
FE034A-19B-A	1920	1822	0.94	.081/.093	.147/.164	.281/.296	.343/.390
FE034A-17B-A	1685	1600	1.07	.093/.098	.164/.187	.296/.312	.390/.406
FE034A-38C-A	3845	3507	0.47	.041/.046	.073/.082	.166/.187	.187/.209
FE034A-34C-A	3375	3078	0.53	.046/.052	.082/.093	.187/.201	.209/.234
FE034A-30C-A	2977	2744	0.60	.052/.059	.093/.104	.201/.221	.234/.265
FE034A-27C-A	2700	2488	0.67	.059/.067	.104/.116	.221/.234	.265/.281
FE034A-24C-A	2400	2235	0.75	.067/.073	.116/.128	.234/.265	.281/.312
FE034A-22C-A	2137	1990	0.83	.073/.081	.128/.147	.265/.281	.312/.343
FE034A-19C-A	1904	1791	0.94	.081/.093	.147/.164	.281/.296	.343/.390
FE034A-17C-A	1699	1598	1.07	.093/.098	.164/.187	.296/.312	.390/.406
FE034A-15C-A	1516	1426	1.20	.098/.109	.187/.204	.312/.328	.406/.421
FE034A-14C-A	1350	1283	1.34	.109/.116	.204/.234	.328/.343	.421/.437
FE034A-12C-A	1199	1139	1.50	.116/.125	.234/.250	.343/.359	.437/.453
FE034A-11C-A	1089	1034	1.66	.125/.140	.250/.265	.359/.375	.453/.468
FE034A-10C-A	959	911	1.88	.140/.161	.265/.281	.375/.390	.468/.484
FE034A-08C-A	842	800	2.14	.161/.187	.281/.312	.390/.406	.484/.531

NOTE: Tools are not supplied with the required motor starter. The starter unit should conform to local/national regulations and must provide overload protection. Complete wiring and connection data are given in the tool's Operator's Manual.

Air Consump. Per Cycle	Operating Sound Level	Stroke Length	Spindle Mount	Motor "B"—Part No. 49685-1 .33 H.P., 3600 R.P.M., 220/270 VC, 380/460 VY, 3 PH, 60 Hz				Motor "C"—Part No. 49685-2 .33 H.P., 1800 R.P.M., 220/270 VC, 380/460 VY, 3 PH, 60 Hz				
				Power Air Inlet	Req. Inlet Hose Size	Remote Control Port Size	Operating Pressure Range	Power Air Inlet	Req. Inlet Hose Size	Remote Control Port Size	Operating Pressure Range	
.014 ft. ³	60 dB (A)	4.33 inches	#33 Jacobs	1/8 N.P.T.	1/4 I.D.	#10-32	50-100	1/8 N.P.T.	1/4 I.D.	#10-32	50-100	
.40 L		110 mm	Male	Female		Female	P.S.I.G.	Female		Female	P.S.I.G.	
Thrust Output, Lbs.	330	314	297	280	264	248	231	215	198	182	165	149
Air Pressure, P.S.I.G.	100	95	90	85	80	75	70	65	60	55	50	45

Electric/Pneumatic Self-Feed Drills



Made in the U.S.A. to the Following Specifications: F E O 5 4 C - 2 2 B - A
 Example of product identification

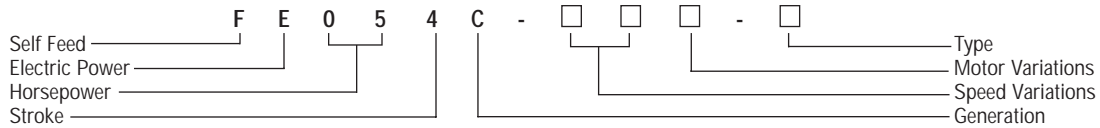

Model Number FE054C(-)-A	Free Speed, R.P.M.	Load Speed Peak H.P. R.P.M.	Torque, Peak H.P. LB. FT.	Stainless 300 Series	Nominal Drilling Capacities Steel S.A.E. 1213	Aluminum 2024-T4	Med. Wood or F.R.P.
FE054C-77B-A	7690	7013	0.32	.018/.020	.036/.046	.070/.101	.078/.096
FE054C-67B-A	6750	6155	0.36	.020/.026	.046/.055	.101/.125	.096/.125
FE054C-59B-A	5954	5486	0.41	.026/.032	.055/.062	.125/.147	.125/.140
FE054C-54B-A	5400	4977	0.46	.032/.038	.062/.073	.147/.169	.140/.156
FE054C-48B-A	4800	4470	0.51	.038/.048	.073/.081	.169/.187	.156/.187
FE054C-43B-A	4274	3979	0.57	.048/.054	.081/.086	.187/.196	.187/.228
FE054C-38B-A	3808	3582	0.65	.054/.060	.086/.093	.196/.228	.228/.250
FE054C-34B-A	3398	3197	0.72	.060/.066	.093/.101	.228/.250	.250/.281
FE054C-30B-A	3031	2851	0.81	.066/.072	.101/.110	.250/.281	.281/.312
FE054C-27B-A	2700	2566	0.91	.072/.078	.110/.125	.281/.296	.312/.343
FE054C-24B-A	2398	2279	1.03	.078/.084	.125/.138	.296/.312	.343/.375
FE054C-22B-A	2178	2070	1.13	.084/.090	.138/.156	.312/.343	.375/.406
FE054C-19B-A	1918	1822	1.28	.090/.096	.156/.187	.343/.375	.406/.437
FE054C-17B-A	1684	1600	1.46	.096/.110	.187/.250	.375/.406	.437/.484
FE054C-38C-A	3845	3507	0.65	.054/.060	.086/.093	.196/.228	.228/.250
FE054C-34C-A	3375	3078	0.72	.060/.066	.093/.101	.228/.250	.250/.281
FE054C-30C-A	2977	2744	0.81	.066/.072	.101/.110	.250/.281	.281/.312
FE054C-27C-A	2700	2488	0.91	.072/.078	.110/.125	.281/.296	.312/.343
FE054C-24C-A	2400	2235	1.03	.078/.084	.125/.138	.296/.312	.343/.375
FE054C-22C-A	2137	1990	1.13	.084/.090	.138/.156	.312/.343	.375/.406
FE054C-19C-A	1904	1791	1.28	.090/.096	.156/.187	.343/.375	.406/.437
FE054C-17C-A	1699	1598	1.46	.096/.110	.187/.250	.375/.406	.437/.484
FE054C-15C-A	1516	1426	1.62	.110/.125	.250/.281	.406/.421	.484/.531
FE054C-14C-A	1350	1283	1.82	.125/.136	.281/.312	.421/.437	.531/.562
FE054C-12C-A	1199	1139	2.05	.136/.152	.312/.343	.437/.453	.562/.593
FE054C-11C-A	1089	1034	2.26	.152/.166	.343/.359	.453/.468	.593/.625
FE054C-10C-A	959	911	2.56	.166/.182	.359/.375	.468/.484	.625/.656
FE054C-08C-A	842	800	2.92	.182/.201	.375/.390	.484/.500	.656/.687

NOTE: Tools are not supplied with the required motor starter. The starter unit should conform to local/national regulations and must provide overload protection. Complete wiring and connection data are given in the tool's Operator's Manual.

Motor "B"—Part No. 49685-3 .50 H.P., 3600 R.P.M., 220/270 VC, 380/460 VY, 3 PH, 50/60 Hz	Motor "C"—Part No. 49685-4 .50 H.P., 1800 R.P.M., 220/270 VC, 380/460 VY, 3 PH, 50/60 Hz											
Air Consump. Per Cycle	Operating Sound Level	Stroke Length	Spindle Mount	Power Air Inlet	Req. Inlet Hose Size	Remote Control Port Size	Operating Pressure Range					
.014 ft. ³	60 dB (A)	4.33 inches	#33 Jacobs	1/8 N.P.T.	1/4 I.D.	#10-32	50-100					
.40 L		110 mm	Male	Female		Female	P.S.I.G.					
Thrust Output, Lbs.	330	314	297	280	264	248	231	215	198	182	165	149
Air Pressure, P.S.I.G.	100	95	90	85	80	75	70	65	60	55	50	45

**INTERCHANGEABLE SPINDLE ACCESSORIES
ADDRESS A MULTITUDE OF NEEDS**

The Electra-Feed Drills can be used with an extensive selection of tapping heads, drill chucks, and collets that can be changed as your secondary machining applications demand.

This flexibility helps ensure that your investment today won't be obsolete tomorrow.

SERIES 34A, 54C & 74B SPINDLE OPTIONS

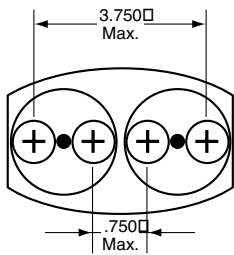

see collets 46033-()

∂
Twin Drill Head 47276
(see chart at right)
adjustable centers

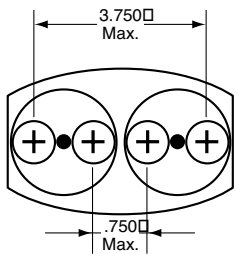

see collets 46033-()

Σ
Twin Tap Head 47908
(see chart at right)
adjustable centers

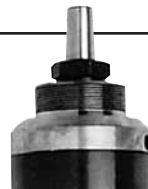
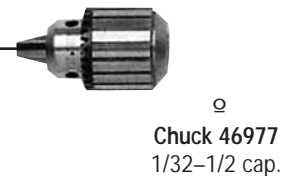

Electric/Pneumatic Self-Feed Drills



Bore Diameter +000/- .0035	Drill Sizes		Twin Drill Collets		Collet No.	Bore Diameter +000/- .0035	Drill Sizes		Collet No.	
	inch	no.	mm	mm			inch	no.		mm
.079"	5/64	47	2.0	46033-1		.228"	1	5.8	46033-39	
.083"		45	2.1	46033-2		.232"	-	5.9	46033-40	
.087"		44	2.2	46033-3		.236"	15/64	A	6.0	46033-41
.091"		43	2.3	46033-4		.240"		B	6.1	46033-42
.094"	3/32	42	2.4	46033-5		.244"		C	6.2	46033-43
.098"		40	2.5	46033-6		.248"		D	6.3	46033-44
.102"		38	2.6	46033-7		.252"	1/4	E	6.4	46033-45
.106"		36	2.7	46033-8		.256"		F	6.5	46033-46
.110"	7/64	35	2.8	46033-9		.260"		G	6.6	46033-47
.114"		33	2.9	46033-10		.264"	17/64	-	6.7	46033-48
.118"		32	3.0	46033-11		.268"		H	6.8	46033-49
.122"		31	3.1	46033-12		.272"		I	6.9	46033-50
.126"	1/8	-	3.2	46033-13		.276"		J	7.0	46033-51
.130"		30	3.3	46033-14		.280"	9/32	K	7.1	46033-52
.134"		29	3.4	46033-15		.283"		-	7.2	46033-53
.138"		-	3.5	46033-16		.287"		-	7.3	46033-54
.142"	9/64	28	3.6	46033-17		.291"		L	7.4	46033-55
.146"		26	3.7	46033-18		.295"		M	7.5	46033-56
.150"		25	3.8	46033-19		.299"	19/64	-	7.6	46033-57
.154"		23	3.9	46033-20		.303"		N	7.7	46033-58
.157"	5/32	22	4.0	46033-21		.307"		-	7.8	46033-59
.161"		20	4.1	46033-22		.311"	5/16	-	7.9	46033-60
.165"		19	4.2	46033-23		.315"		O	8.0	46033-61
.169"		18	4.3	46033-24		.319"		-	8.1	46033-62
.173"	11/64	17	4.4	46033-25		.323"		P	8.2	46033-63
.177"		16	4.5	46033-26		.327"	21/64	-	8.3	46033-64
.181"		14	4.6	46033-27		.331"		Q	8.4	46033-65
.185"		13	4.7	46033-28		.335"		-	8.5	46033-66
.189"	3/16	12	4.8	46033-29		.339"		R	8.6	46033-67
.193"		10	4.9	46033-30		.342"	11/32	-	8.7	46033-68
.197"		9	5.0	46033-31		.346"		-	8.8	46033-69
.201"		7	5.1	46033-32		.350"		S	8.9	46033-70
.205"	13/64	5	5.2	46033-33		.354"		-	9.0	46033-71
.209"		4	5.3	46033-34		.358"	23/64	T	9.1	46033-72
.213"		3	5.4	46033-35		.362"		-	9.2	46033-73
.216"		-	5.5	46033-36		.366"		-	9.3	46033-74
.220"	7/32	2	5.6	46033-37		.370"		U	9.4	46033-75
.224"		-	5.7	46033-38		.375"	3/8	-	9.5	46033-76

Tap Size	Σ Twin Tap Collets					
	#0-#6	#8	#10	#12	1/4	5/16

Tap Adapters for Quick Change Tapping Head

Part No.	Adapter	Tap size	Drive
49766-1	Adapter	#0-#6	Positive Drive
49766-2	Adapter	#8	Positive Drive
49766-3	Adapter	#10	Positive Drive
49766-4	Adapter	1/4	Positive Drive
49766-5	Adapter	#0-#6	Torque Control
49766-6	Adapter	#8	Torque Control
49766-7	Adapter	#10	Torque Control
49766-8	Adapter	1/4	Torque Control

[] Series 48175 Specifications
 Length: 3 5/16 (84 mm)
 Taper: No. 33 Jacobs
 Outside Diameter: 1 3/4 (44 mm)
 Approx. Tooling Penetration: 1 7/8 (42.6 mm)
 Subassemblies: 48091 body
 35264-() insert

Collet No.	Size range		Insert
	in.	(mm)	
48175-1	7/32 - 1/4	(5.5-6.4)	35264-1
48175-2	1/4 - 9/32	(6.4-7.1)	35264-2
48175-3	9/32 - 5/16	(7.1-7.9)	35264-3
46175-4	5/16 - 11/32	(7.9-8.7)	35264-4
48175-5	11/32 - 3/8	(8.7-9.5)	35264-5
48175-6	3/8 - 13/32	(9.5-10.3)	35264-6
48175-7	13/32 - 7/16	(10.3-11.1)	35264-7
48175-8	7/16 - 15/32	(11.1-11.9)	35264-8
48175-9	15/32 - 1/2	(11.9-12.7)	35264-9
48175-10	1/2 - 17/32	(12.7-13.5)	35264-10
48175-11	17/32 - 9/16	(13.5-14.3)	35264-11
46175-12	9/16 - 19/32	(14.3-15.1)	35264-12
48175-13	19/32 - 5/8	(15.1-15.9)	35264-13
48175-14	5/8 - 21/32	(15.9-16.6)	35264-14
48175-15	21/32 - 11/16	(16.6-17.4)	35264-15
48175-16	11/16 - 23/32	(17.4-18.2)	35264-16
48175-17	23/32 - 3/4	(18.2-19.0)	35264-17

Wedge Set	
46983	To remove chuck from tapered spindle

Control Accessories	
49785	Switch Kit; Provides output for electric "Tool is Forward" or "Tool is Retracted" signals (AC or DC)
49786	Solenoid Kit; 120 VAC Provides input for remote "Start" or "Emergency Retract" signals
49787	Solenoid Kit; 24 VDC Provides input for remote "Start" or "Emergency Retract" signals
59764-4	Connector (10 pcs./box) Used to connect input & output ports to air signal tubing. Shown on page 37.

Feed Rate Controls	
Part No.	
38922	1" Stroke Hydraulic Check
38922-1	2" Stroke Hydraulic Check
38922-2	3" Stroke Hydraulic Check

Pneumatic Self-Feed Drills



ARO Bant-A-Matic, Par-A-Matic, and Super Par-A-Matic Drills provide the selection, performance, and degree of precision to automate a wide range of secondary machining applications simply and economically. They utilize compressed air for both the spindle rotation and feed / control functions. The reliable rotary-vane air motor offers high power-to-size performance which minimizes tool size and weight for added machine design flexibility. The tools are easily installed, requiring only simple pneumatic circuitry. They can be used individually or in conjunction with other ARO electric and pneumatic tools.

Additional features / benefits include—

- Built-in four-way valve enables both manual and remote operation.
- Double-acting air piston provides smooth, controlled forward and retract strokes.
- Needle valve controls allows adjustment of forward and retract strokes.
- Adjustment screw provides infinite stroke length settings.
- Ball bearing spindle support offers precision and long service life.
- Muffled exhaust for a quieter work environment.

BANT-A-MATIC[®] SERIES

3/16" (4.8 mm) Capacity, Steel • .25 HP (.20 kW)



MODEL 8245-B45-2

PAR-A-MATIC[®] SERIES

5/16" (7.9 mm) Capacity, Steel • .50 HP (.37 kW)



MODEL 8255-A14-2

SUPER PAR-A-MATIC[®] SERIES

1/2" (12.7 mm) Capacity, Steel • .75 HP (.56 kW)



MODEL 8265-25-3

MODEL IDENTIFICATION

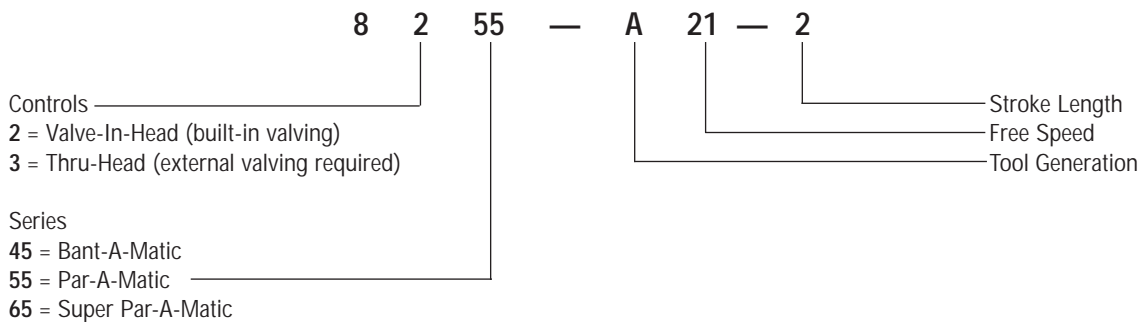

Pneumatic Self-Feed Drills



SPECIFICATIONS

MODELS & STROKE LENGTHS			FREE SPEED rpm	*NOMINAL DRILLING CAPACITIES				THRUST @90 PSI (N)	AIR CONSP. † @Working Speed (ft ³ /cycle (L/cycle))	SOUND LEVEL dB(A)	STD. CHUCK CAPACITY in. (mm)	GEAR REDUCTION
Stnls. Type	Steel 304	Steel SAE 1213	Aluminum 2024-T4	Wood, Med. or FRP								
BANT-A-MATIC SERIES												
1-1/4" (32 mm)	2.0" (51 mm)	3.0" (76 mm)										
*8245-203-1	8245-203-2	8245-203-3	19,000	—	1/64 (0.4)	1/32 (0.8)	1/16 (1.6)				Single	
8245-101-1	8245-101-2	8245-101-3	10,000	—	1/64 (0.4)	1/32 (0.8)	1/16 (1.6)	1/8 (3.2)			Double	
8245-B45-1	8245-B45-2	8245-B45-3	4,400	1/32 (0.8)	1/16 (1.6)	1/8 (3.2)	5/32 (4.0)	90 (400)	1.5 (42)	77	1/4 (6.4) Single	
8245-B30-1	8245-B30-2	8245-B30-3	2,700	1/16 (1.6)	1/8 (3.2)	3/16 (4.8)	3/16 (4.8)				Single	
8245-B8-1	8245-B8-2	8245-B8-3	900	3/32 (2.4)	3/16 (4.8)	1/4 (6.4)	5/16 (7.9)				Double	
PAR-A-MATIC SERIES												
1-1/4" (32 mm)	2.0" (51 mm)	3.0" (76 mm)										
*8255-172-1	8255-172-2	8255-172-3	17,000	—	1/64 (0.4)	1/32 (0.8)	1/16 (1.6)				Single	
8255-101-1	8255-101-2	8255-101-3	10,000	—	1/32 (0.8)	1/16 (1.6)	5/32 (4.0)				Double	
8255-A50-1	8255-A50-2	8255-A50-3	5,000	—	5/64 (2.0)	3/16 (4.8)	3/16 (4.8)				Single	
8255-A28-1	8255-A28-2	8255-A28-3	2,800	1/16 (1.6)	9/64 (3.6)	1/4 (6.4)	1/4 (6.4)				Single	
8255-A21-1	8255-A21-2	8255-A21-3	2,100	7/64 (2.8)	7/32 (5.6)	9/32 (7.1)	5/16 (7.9)	170 (756)	2.3 (65)	74	5/16 (79) Single	
8255-A14-1	8255-A14-2	8255-A14-3	1,450	5/32 (4.0)	1/4 (6.4)	5/16 (7.9)	3/8 (9.5)				Double	
8255-A8-1	8255-A8-2	8255-A8-3	850	11/64 (4.4)	9/32 (7.1)	21/64 (8.3)	25/64 (9.9)				Double	
8255-A5-1	8255-A5-2	8255-A5-3	500	1/4 (6.4)	5/16 (7.9)	11/32 (8.7)	13/32 (10.3)				Double	
SUPER PAR-A-MATIC SERIES												
1-1/2" (38 mm)		3.0" (76 mm)										
*8265-171-1		8265-171-3	17,000	—	1/64 (0.4)	3/32 (2.4)	3/32 (2.4)				Single	
8265-101-1		8265-101-3	10,000	—	3/64 (1.2)	5/32 (4.0)	5/32 (4.0)				Double	
8265-46-1		8265-46-3	4,600	—	1/8 (3.2)	1/4 (6.4)	5/16 (7.9)				Single	
8265-25-1		8265-25-3	2,500	3/32 (2.4)	3/16 (4.8)	5/16 (7.9)	7/16 (11.1)	250 (1112)	2.9 (82)	77	1/2 (12.7) Single	
8265-12-1		8265-12-3	1,200	5/32 (4.0)	5/16 (7.9)	3/8 (9.5)	9/16 (14.3)				Double	
8265-6-1		8265-6-3	650	17/64 (6.7)	7/16 (11.1)	9/16 (14.3)	5/8 (15.9)				Double	
8265-3-1		8265-3-3	350	5/16 (7.9)	1/2 (12.7)	5/8 (15.9)	11/16 (17.5)				Double	

*NOTE: 17,000 & 19,000 RPM units have collet in Spindle. See Pages 52, 54 & 56.

†Consumption in cubic feet during a typical 6 second cycle time. Note: Performance data given at 90 PSI (6.2 bar) operating pressure.

TOOL SERIES	AIR INLET	CONTROL PORTS	SPINDLE THREAD	RECOMMENDED HOSE SIZE	RECOMMENDED OPERATING PRESSURE
Bant-A-Matic	1/8" NPT male	1/8" NPTF female	1/2"-20 male	1/4" ID	90 PSI (6.2 bar)
Par-A-Matic	1/4" NPT male	1/8" NPTF female	1/2"-20 male	5/16" ID	90 PSI (6.2 bar)
Super Par-A-Matic	1/4" NPT male	1/8" NPTF female	1/2"-20 male	3/8" ID	90 PSI (6.2 bar)

To order a "thru-head" tool (requires an external four-way valve for controls), change the "2" in the base model number to "3" (Bant-A-Matic and Par-A-Matic Series tools only). EXAMPLE: 8355-A21-2. Thru-head tools available in Super Par-A-Matic series only as a custom order tool. 47884 Pneumatic Interface Kit contains 2 each of 6045 elbow and 9600 bleeder valve.

STANDARD EQUIPMENT

Bant-A-Matic Series

- 33906 1/4" (6.4 mm) Cap. Chuck*
- 47884 Pneumatic Controls Interface Kit*
- 203 UNITS have collet built-in spindle instead of chuck. See page 63 for selection of collet

Par-A-Matic Series

- 33907 3/8" (9.5 mm) Cap. Chuck*
- 47884 Pneumatic Controls Interface Kit*
- 172 UNITS have collet built-in spindle instead of chuck. See page 63 for selection of collet

Super Par-A-Matic Series

- 30018 1/2" (12.7 mm) Cap. Chuck*
- 47884 Pneumatic Controls Interface Kits*
- 171 UNITS have collet built-in spindle instead of chuck. See page 63 for selection of collet

ACCESSORIES AT EXTRA COST

Bant-A-Matic Series

- 40301-() Hydraulic Checks
- 39486 Flange Bracket
- 39485-1 Foot Bracket
- 45053 H.D. Foot Bracket
- 36042 Split-Block Clamp
- Nose Housings
- Drill Bushing Adapters
- Control Kits
- Service Kits

Par-A-Matic Series

- 40591-() Hydraulic Checks
- 38877 Flange Bracket
- 38875-1 Foot Bracket
- 45055 H.D. Foot Bracket
- 35283 Split-Block Clamp
- Nose Housings
- Drill Bushing Adapters
- Control Kits
- Service Kits

Super Par-A-Matic Series

- 40591-() Hydraulic Checks
- 40589 Flange Bracket
- 40588-1 Foot Bracket
- 45056 H.D. Foot Bracket
- 41454 Collet-Type Foot Bracket
- Nose Housings
- Nose Housing Adapters
- Drill Bushing Adapters
- Control Kits
- Service Kits

Pneumatic Self-Feed Twin Drills



ARO Twin Drills perform two machining operations per cycle for holes with center distances from 3/8" to 3 3/4". They're ideal for many close-center machining problems. But even more important, ARO Twin Drills significantly reduce machining time and parts handling while improving quality.

Three series of standard tools are available, equipped with adjustable dual spindle heads. Like the other ARO Automatic Production Tools, each Twin Drill is a completely self-contained unit with built-in cycle, feed rate, and motor controls. They can be operated individually or in conjunction with other tools and machine components.

Additional features / benefits include—

- Adjustable spindles allow reapplication as machining requirements change.
- Comprehensive range of American and metric collets available to meet a wide variety of hole specifications.
- Double-acting air piston provides smooth, controlled forward and retract strokes.
- Needle valve controls allow adjustment of forward and retract strokes.
- Adjustment screw provides infinite stroke length settings up to 3.0" maximum.
- Muffled exhaust for a quieter work environment.

BANT-A-MATIC[®] SERIES

1/8" (3.2 mm) Capacity, Steel • .25 HP (.19 kW)



MODEL 8248-B30-2

PAR-A-MATIC[®] SERIES

1/4" (6.4 mm) Capacity, Steel • .50 HP (.37 kW)



MODEL 8258-C21-2

SUPER PAR-A-MATIC[®] SERIES

3/8" (9.5 mm) Capacity, Steel • .75 HP (.56 kW)



MODEL 8268-A25-3

MODEL IDENTIFICATION

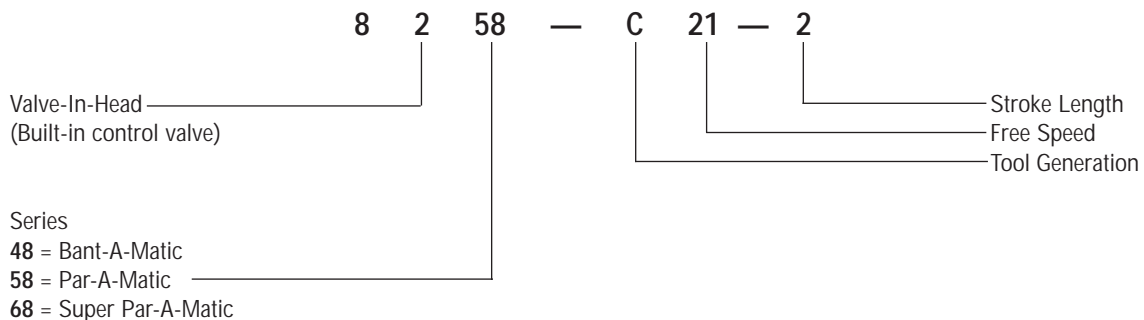

Pneumatic Self-Feed Twin Drills



SPECIFICATIONS

MODELS & STROKE LENGTHS			FREE SPEED rpm	*Stnls. Steel Type 304	*NOMINAL DRILLING CAPACITIES Steel SAE 1213	Aluminum 2024-T4	Wood, Med. or FRP	THRUST @90 PSI lb. (N)	AIR CONSP. † @Working Speed ft ³ /cycle (L/cycle)	SOUND LEVEL dB(A)	STD. CHUCK CAPACITY in. (mm)	GEAR REDUCTION
BANT-A-MATIC SERIES												
1-1/4" (32 mm)	2.0" (51 mm)	3.0" (76 mm)										
8248-B45-1	8248-B45-2	8248-B45-3	4,400	1/32 (.78)	1/16 (1.6)	3/32 (2.4)	3/32 (2.4)					Single
8248-B30-1	8248-B30-2	8248-B30-3	2,700	1/16 (1.6)	3/32 (2.4)	1/8 (3.2)	1/8 (3.2)	90 (400)	1.5 (42)	77	5/32 (4.0)	Single
8248-B8-1	8248-B8-2	8248-B8-3	900	1/8 (3.2)	1/8 (3.2)	3/16 (4.8)	3/16 (4.8)					Double
PAR-A-MATIC SERIES												
1-1/4" (32 mm)	2.0" (51 mm)	3.0" (76 mm)										
8258-C50-1	8258-C50-2	8258-C50-3	5,000		1/16 (1.6)	1/8 (3.2)	1/8 (3.2)					Single
8258-C28-1	8258-C28-2	8258-C28-3	2,800	3/64 (1.2)	1/8 (3.2)	3/16 (4.5)	3/16 (4.5)					Single
8258-C21-1	8258-C21-2	8258-C21-3	2,100	5/64 (1.9)	5/32 (4.0)	7/32 (5.6)	7/32 (5.6)	170 (756)	2.3 (65)	74	1/4 (6.4)	Single
8258-C14-1	8258-C14-2	8258-C14-3	1,450	7/64 (2.7)	3/16 (4.5)	1/4 (6.4)	1/4 (6.4)					Double
8258-C8-1	8258-C8-2	8258-C8-3	850	11/64 (4.3)	1/4 (6.4)	9/32 (7.1)	9/32 (7.1)					Double
8258-C5-1	8258-C5-2	8258-C5-3	500	1/4 (6.4)	1/4 (6.4)	5/16 (7.9)	5/16 (7.9)					Double
SUPER PAR-A-MATIC SERIES												
1-1/2" (38 mm)	3.0" (76 mm)											
8268-A46-1	8268-A46-3		4,600			1/4 (6.4)	3/16 (4.8)					Single
8268-A25-1	8268-A25-3		2,500	1/16 (1.6)	1/4 (6.4)	5/16 (7.9)	5/16 (7.9)					Single
8268-A12-1	8268-A12-3		1,200	1/8 (3.2)	5/16 (7.9)	11/32 (8.7)	3/8 (9.5)	250 (1112)	2.9 (82)	77	3/8 (9.5)	Double
8268-A6-1	8268-A6-3		650	13/64 (5.2)	11/32 (8.7)	3/8 (9.5)	7/16 (11.1)					Double
8268-A3-1	8268-A3-3		350	5/16 (7.9)	3/8 (9.5)	13/32 (10.3)	15/32 (11.9)					Double

*Speed Sensitive Material †Consumption in cubic feet during a typical 6 second cycle time. Note: Performance data given at 90 PSI (6.2 bar) operating pressure.

TOOL SERIES	SPINDLE ADJUSTMENT	AIR INLET	CONTROL PORTS	RECOMMENDED HOSE SIZE	RECOMMENDED OPERATING PRESSURE
Bant-A-Matic	3/8" to 2 1/8" centers (9.5 to 54 mm)	1/8" NPT male	1/8" NPTF female	1/4" ID	90 PSI (6.2 bar)
Par-A-Matic	1/2" to 2 1/2" centers (12.7 to 63.5 mm)	1/4" NPT male	1/8" NPTF female	5/16" ID	90 PSI (6.2 bar)
Super Par-A-Matic	3/4" to 3 3/4" centers (19 to 95 mm)	1/4" NPT male	1/8" NPTF female	3/8" ID	90 PSI (6.2 bar)

STANDARD EQUIPMENT

Bant-A-Matic Series

- 46394 Twin Drill Head
- 47884 Pneumatic Controls Interface Kit*
- Necessary Wrenches

*Contains (2) 6045 90° street elbows and (2) 9600 pilot bleeder valves.

Par-A-Matic Series

- 46023 Twin Drill Head
- 47884 Pneumatic Controls Interface Kit*
- Necessary Wrenches

Super Par-A-Matic Series

- 46063 Twin Drill Head
- 47884 Pneumatic Controls Interface Kit*
- Necessary Wrenches

NOTE: Collets for Twin Drills must be ordered separately at extra cost. See page 28.

ACCESSORIES AT EXTRA COST

Bant-A-Matic Series

- 47368-() Collets
- 40301-() Hydraulic Checks
- 39486 Flange Bracket
- 39485-1 Foot Bracket
- 45053 H.D. Foot Bracket
- 36042 Split-Block Clamp
- Control Kits
- Service Kits

Par-A-Matic Series

- 45998-() Collets
- 40591-() Hydraulic Checks
- 38877 Flange Bracket
- 38875-1 Foot Bracket
- 45055 H.D. Foot Bracket
- 35283 Split-Block Clamp
- Control Kits
- Service Kits

Super Par-A-Matic Series

- 46033-() Collets
- 40591-() Hydraulic Checks
- 40589 Flange Bracket
- 40588-1 Foot Bracket
- 45056 H.D. Foot Bracket
- 41454 Collet-Type Foot Bracket
- Control Kits
- Service Kits

Pneumatic Self-Feed Offset Drills



ARO Automatic Offset Drills are offered to accommodate unusual part or fixture configurations. They also may be grouped in a fixture to produce holes with a center-line distance as low as 1.5".

Offset drills are easily installed, requiring only simple pneumatic circuitry. They may also be used in conjunction with other pneumatic or electric ARO Automatic Production Tools.

Additional features / benefits include—

- Built-in four-way valve for both manual and remote operation.
- Double-acting air piston provides smooth, controlled forward and retract strokes.
- Infinite stroke length adjustment up to 2.0" maximum.
- Feed rate adjustment screws for the forward and retract strokes provide optimum hole quality and cycle time.
- Muffled exhaust for a more comfortable work environment.
- Selection of mounting brackets to meet installation requirements.

PAR-A-MATIC® SERIES

3/16" (4.8 mm) Capacity, Steel • 50 HP (.37 kW)



MODEL 8266-A17-2

SPECIFICATIONS

MODELS	FREE SPEED rpm	NOMINAL DRILLING CAPACITIES				THRUST @90 PSI lb. (N)	AIR CONSP.‡ @Working Speed ft ³ /cycle (L/cycle)	SOUND LEVEL dB(A)	STD. CHUCK CAPACITY in. (mm)	GEAR REDUCTION
		Stnls. Steel Type 304	Steel SAE 1213	Aluminum 2024-T4	Wood, Med. or FRP					
8266-A23-2	2,300	N/A	1/16 (1.6)	1/8 (3.2)	3/16 (4.8)				Double	
8266-A17-2	1,750	N/A	3/32 (2.4)	5/32 (4.0)	7/32 (5.6)	170 (756)	2.3 (65)	74	3/8 (9.5)	Double
8266-A12-2	1,200	N/A	5/32 (4.0)	3/16 (4.8)	1/4 (6.4)					Double
8266-A72	700	N/A	3/16 (4.8)	7/32 (5.6)	9/32 (7.2)					Double

‡Consumption in cubic feet during a typical 6 second cycle time. Note: Performance data given at 90 PSI (6.2 bar) air pressure.

AIR INLET	CONTROL PORTS	SPINDLE THREAD	RECOMMENDED HOSE SIZE	RECOMMENDED OPERATING PRESSURE
1/4" NPT male	1/8" NPTF female	3/8"-24 male	5/16" ID	90 PSI (6.2 bar)

STANDARD EQUIPMENT

- 47341 3/8" (9.5 mm) Cap. Chuck
- 47884 Pneumatic Controls Interface Kit—contains (2) 6045 90° street elbows and (2) 9600 pilot bleeder valves

ACCESSORIES AT EXTRA COST

- 40591-() Hydraulic Checks
- 38877 Flange Bracket
- 38875-1 Foot Bracket
- 45055 H.D. Foot Bracket
- 35283 Split-Block Clamp
- Control Kits
- Service Kits



ARO Peck-Feed Drills are designed specifically for applications where the hole depth exceeds four times the diameter of the drill bit. They offer the advantages of deep-hole chip clearance with close diameter and axial controls.

The ARO Peck-Feed Drill is a complete, self-contained unit. The pecking operation is controlled by a pre-set, timed sequence. Upon receiving a start signal, the tool automatically advances, drills to a selected peck depth and retracts, continuing the cycle until the total hole depth is reached. This sequential pecking action clears the hole and drill flutes of chips that produce frictional heat, drag, and drill skew. It also greatly increases the life of small drills (3/32 thru No. 80) that are sensitive to excessive thrust and radial loading.

Additional features / benefits include—

- Manual and remote operation.
- Muffled exhaust for a more comfortable work environment.
- Selection of mounting brackets to meet installation requirements.

PAR-A-MATIC® SERIES

5/16" (7.9 mm) Capacity, Steel • .50 HP (.37 kW)



MODEL 8360-A28-3



SPECIFICATIONS

MODELS	FEED SPEED rpm	THRUST @90 PSI lb. (N)	FREE RATE in./m (mm/m)	STROKE LENGTH in. (mm)	PECK RANGE in. (mm)	RAPID ADVANCE RANGE in. (mm)	AIR CONSP.† @WORKING SPEED ft ³ /cycle (L/cycle)	SOUND LEVEL dB(A)	STD. CHUCK CAPACITY in. (mm)	GEAR REDUCTION
*8360-172-3	17,000									Single
8360-A50-3	5,000									Single
8360-A28-3	2,800		0 min to 40 max.	29/32 to 2 1/4	5/16 min to 1-21/32 max					Single
8360-A21-3	2,100	170 (756)	(0 to 1016)	2.75 (6.99)	(23 to 57)	(7.9 to 42)	2.3 (65)	74	3/8 (9.5)	Single
8360-A14-3	1,450									Double
8360-A8-3	850									Double
8360-A5-3	500									Double

*NOTE: 17,000 RPM unit has collet in spindle. See page 59.

†Consumption in cubic feet for a full minute of operation. Note: Performance data given at 90 PSI (6.2 bar) air pressure.

Tool	AIR INLET Peck Box	CONTROL PORTS Peck Box	SPINDLE THREAD	RECOMMENDED HOSE SIZE	RECOMMENDED OPERATING PRESSURE
1/4" NPT male	5/32" Tubing	5/32" Tube Connection	1/2"-20 male	5/16" ID	90 PSI (6.2 bar)

STANDARD EQUIPMENT

- 33907 3/8" (9.5 mm) Cap. Chuck
- Peck-Feed Control

ACCESSORIES AT EXTRA COST

- 38877 Flange Bracket
- 38875-1 Foot Bracket
- 45055 H.D. Foot Bracket
- 35283 Split-Block Clamp
- Nose Housing
- Drill Bushing Adapter
- Service Kits

HIGH-THRUST 8670 SERIES

5/8" (15.9 mm) Capacity, Steel • 1.25 HP (.93 kW)



MODEL 8670-28-1

ARO Hi-Thrust Automatic Feed Drills are designed for increased material removal rates of standard alloys and non-ferrous materials. Their high power and thrust also enable the machining of even the most demanding materials, including titanium and high-nickel alloys.

ARO Hi-Thrust Drills feature a dual piston which develops the increased thrust for fast penetration and reduced cycle times. The tools are fully automatic, with all cycle and motor functions regulated by a single control module. They are easily installed, requiring only simple pneumatic circuitry. Hi-Thrust Drills can also be used in conjunction with other pneumatic and electric ARO Automatic Production Tools.

Additional features / benefits include—

- Adjustable hydraulic check provides positive feed rate control for fine adjustment of chip size or breakthrough control.

- "Dead stop" and "dwell" control offer repeatable depth accuracy within .001".
- Heavy-duty cast iron housing for rigid mounting.
- Constant tool length, regardless of spindle speed, allows speed change without repositioning the tool.
- Both coarse and fine stroke length adjustments enables quick, accurate setups.
- Control module is a complete, replaceable unit and can be easily removed without tool disassembly.
- Modular motor and gearing units enable fast, easy speed changes and servicing.
- Single exterior lubrication point for entire gear train simplifies preventative maintenance.
- Muffled exhaust for a more comfortable work environment.
- Exhaust may be piped away.

MODEL IDENTIFICATION

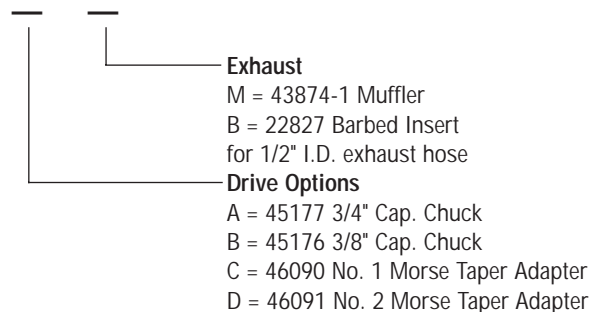
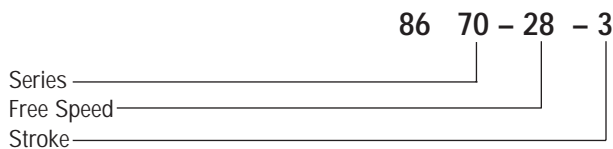



8670 SPECIFICATIONS

MODEL	FREE SPEED rpm	NOMINAL DRILLING CAPACITIES				THRUST @90 PSI lb. (N)	AIR CONSP.† @Working Speed ft ³ /cycle (L/cycle)	SOUND LEVEL dB(A)	STD. CHUCK CAPACITY in. (mm)	STROKE LENGTH in. (mm)
		Stnls. Steel Type 304	Steel SAE 1213	Aluminum 2024-T4	Wood, Med. or FRP					
8670-47-3	4,700	—	3/16 (4.75)	7/16 (11.1)	1/2 (12.7)					
8670-28-3	2,800	3/16 (4.8)	1/4 (6.35)	9/16 (14.3)	5/8 (15.9)					
8670-13-3	1,350	5/16 (7.9)	11/32 (8.73)	5/8 (15.9)	3/4 (19.0)	500 (2224)	5.0 (142)	80	3/4 (19.0) 3.0 (76)	
8670-8-3	800	3/8 (9.5)	7/16 (11.11)	3/4 (19.0)	7/8 (22.2)					
8670-4-3	450	1/2 (12.7)	5/8 (15.87)	7/8 (22.2)	1.0 (25.4)					

†Consumption in cubic feet during a typical 6 second cycle time. Note: Performance data given at 90 PSI (6.2 bar) air pressure.

AIR INLET	CONTROL PORTS	SPINDLE THREAD	RECOMMENDED HOSE SIZE	RECOMMENDED OPERATING PRESSURE	COUPLER/CONNECTION	F/R/L
3/8" NPT male	1/8" NPTF female	5/8"-16 male	5/8" I.D.	90 PSIG (6.2 bar)	1/2"	1/2"

STANDARD EQUIPMENT (As ordered. See model identification.)

- 45177 3/4" (19 mm) Cap. Chuck
- 38922-1 2.0" Hydraulic Check
- 45940 Exhaust Manifold
- 43874-1 Muffler or 2632 Barbed Insert
- Necessary wrenches
- 45176 3/8" (9.5 mm) Cap. Chuck
- 46090 No. 1 Morse Taper Adapter
- 46091 No. 2 Morse Taper Adapter

ACCESSORIES AT EXTRA COST

- 38922-2 3.0" Hydraulic Check
- 46133-() Twin Hydraulic Check Assembly
- 45185 Foot Bracket
- 45188 Nose Housing
- 46093-() Collets

Pneumatic Self-Feed Tappers



These tools are identical to the Bant-A-Matic and Par-A-Matic units described on pages 12 and 13, except that these are fitted with tapping heads. All models are completely self-contained and have an adjustable stroke length of 2.0" maximum.

These tools are ideal for low-cost, automated hole tapping in applications where high precision is not required. Also excellent for thread-chasing operations.

Clutch-type tapping units may be used for both blind and thru-hole applications. Jaw-type units are for use in thru-hole applications only.

BANT-A-MATIC® SERIES Clutch-Type Tapping Head

No. 0 to 1/4" (M1.6 to M6) Capacity, Steel
.25 HP (.20 kW)



MODEL 8246-D8-2

PAR-A-MATIC® SERIES Clutch-Type Tapping Head

No. 0 to 1/2" (M1.6 to M12) Capacity, Steel
.50 HP (.37 kW)

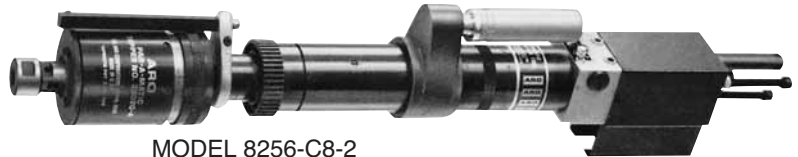

MODEL 8256-C8-2

PAR-A-MATIC® SERIES Jaw-Type Tapping Head

No. 10 to 5/16" (M4.5 to M8) Capacity, Steel
.50 HP (.37 kW)

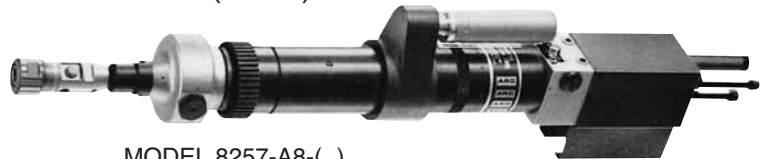

MODEL 8257-A8-()

MODEL IDENTIFICATION

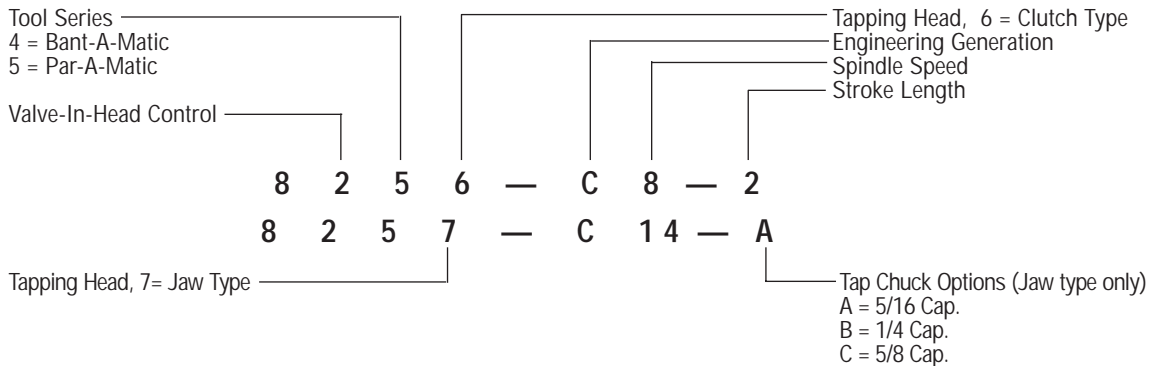



SPECIFICATIONS

MODELS	STROKE LENGTH in. (mm)	FREE SPEED rpm	NOMINAL TAP CAPACITIES			HAND TAP CAPACITY	AIR CONSP† @ Working Speed		SOUND LEVEL dB(A)	GEAR REDUCTION
			Stnls. Steel Type 304	Mild Steel	Aluminum/ Brass		ft ³ /cycle	(L/cycle)		
BANT-A-MATIC SERIES (Clutch-Type)										
8246-D8-2	2.0 (51)	900		#8 (M6)	1/4 (M6)	No. 0-1/4"	15	(42)	77	Double
8246-D5-2	2.0 (51)	550		1/4 (M6)	1/4 (M6)**	(M1.6-M6)				Double
PAR-A-MATIC SERIES (Clutch-Type)										
8256-C14-2	2.0 (51)	1,450		#10 (M5)	1/4 (M6)		2.3	(65)	74	Double
8256-C8-2	2.0 (51)	850		5/16 (M8)	3/8	No. 0- 1/2"				Double
8256-C5-2	2.0 (51)	500		1/2 (M12)	1/2 (M12)	(M1.6-M12)				Double
PAR-A-MATIC SERIES (Jaw-Type)										
8257-A14-()	2.0 (51)	1,450		#10 (M5)	1/4 (M6)		2.3	(65)	74	Double
8257-A8-()	2.0 (51)	850		5/16 (M8)	3/8	No. 10-5/16"				Double
8257-A5-()	2.0 (51)	500		1/2 (M12)	9/16 (M14)	(M4.5-M8)				Double

† Consumption in cubic feet during a typical 6 second cycle time. **Tapping capacity is limited by the capacity of the tap chuck.
NOTE: Performance data given at 90 PSI (6.2 bar) air pressure.

TOOL SERIES	AIR INLET	CONTROL PORTS	SPINDLE THREAD	RECOMMENDED HOSE SIZE	RECOMMENDED OPERATING PRESSURE
Bant-A-Matic	1/8" NPT male	1/8" NPT female	1/2"-20 male	1/4" ID	90 PSI (6.2 bar)
Par-A-Matic	1/4" NPT male	1/8" NPT female	1/2"-20 male	5/16" ID	90 PSI (6.2 bar)

STANDARD EQUIPMENT

Bant-A-Matic Series (Clutch-Type)

- 42123-1 Tapping Head Attachment
- 37431-2 No. 0-No. 10 Cap. Rubber Flex Collet Insert
- 37431-3 No. 10-1/4" Cap. Rubber Flex Collet Insert
- 47884 Pneumatic Controls Interface Kits*
- Necessary Wrenches

Par-A-Matic Series (Clutch-Type)

- 38021-4 Tapping Head Attachment
- 38036 No. 0-1/4" Cap. Rubber Flex Collet Insert
- 38036-1 No. 1/4-1/2" Cap. Rubber Flex Collet Insert
- 47884 Pneumatic Controls Interface Kits*
- Necessary Wrenches

Par-A-Matic Series (Jaw-Type)

- 34000-1 Tapping Head Attachment
- 31432 No. 10-5/16" Cap. Tap Chuck (See Model Identification Chart on page 20)
- 31427 No. 1/4 Cap. Tap Chuck (See Model Identification Chart on page 20)
- 32060 No. 1/4-5/8" Cap. Tap Chuck (See Model Identification Chart on page 20)
- 47884 Pneumatic Controls Interface Kits*
- Necessary Wrenches

*Contains (2) 6045 90° street elbows and (2) 9600 pilot bleeder valves.

ACCESSORIES AT EXTRA COST

Bant-A-Matic Series

- 40301-() Hydraulic Checks
- 39486 Flange Bracket
- 39485-1 Foot Bracket
- 45053 H.D. Foot Bracket
- 36042 Split-Block Clamp
- Service Kits

Par-A-Matic Series

- 40591-() Hydraulic Checks
- 38877 Flange Bracket
- 38875-1 Foot Bracket
- 45055 H.D. Foot Bracket
- 35283 Split-Block Clamp
- Service Kits

Pneumatic Lead Screw Tappers

DOBCO
EQUIPMENT LTD

2200 SERIES

1/2" (M12) Capacity, Steel
.62 HP (.47 kW)

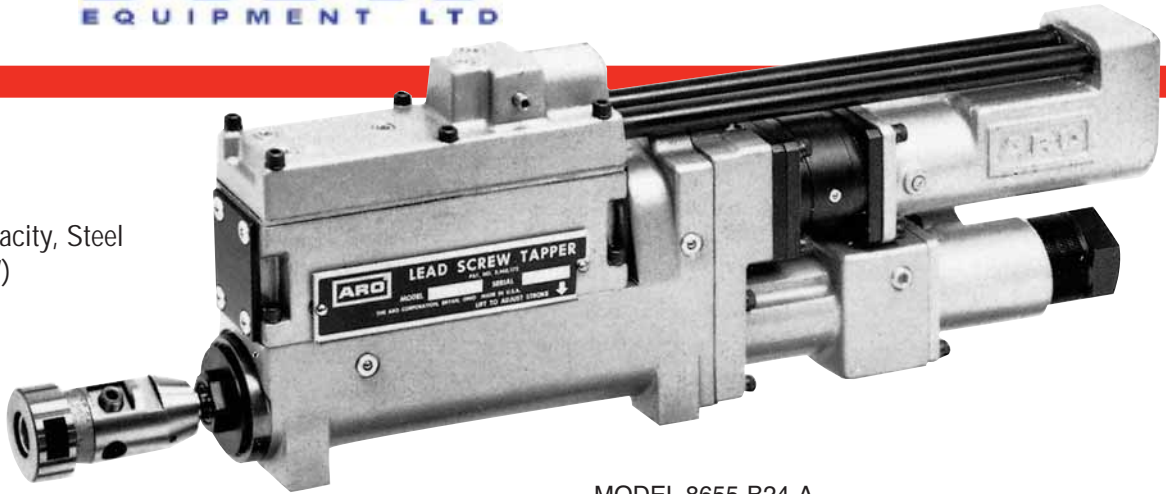

MODEL 8655-B24-A

The ARO Lead Screw Tapper is designed for precision hole tapping in medium and high-production machining applications. The tool is air operated and is fully automatic, with a built-in pressure-operated valve, manual controls and remote control ports for starting and retracting. Installation is easy, with only simple pneumatic circuitry required. It can be used individually or in conjunction with other pneumatic and electric self-feed tools and machine components.

Additional features/benefits include—

- Repeatability tapping depth accuracy of $\pm .005"$ (.127 mm).
- Stroke length is fully adjustable from 3/16" (4.8 mm) minimum to 2.0" (50.8 mm) maximum for use in a wide range of setups.
- A built-in "no-hole" sensing system prolongs tap life by automatically retracting the spindle when a pilot hole is missing or when excessive misalignment exists.
- Modular tool design enables easy servicing of air motor and gearing, and offers convenient, economical speed and lead screw conversions as job requirements change.
- Compact size requires less machine space for increased design flexibility.
- Fixed-position foot mounting requires no additional mounting hardware while providing added rigidity.
- A wide selection of models is available for both American and metric threads.
- Twin and multi-spindle tapping heads are available for close-center machining requirements.

MODEL IDENTIFICATION

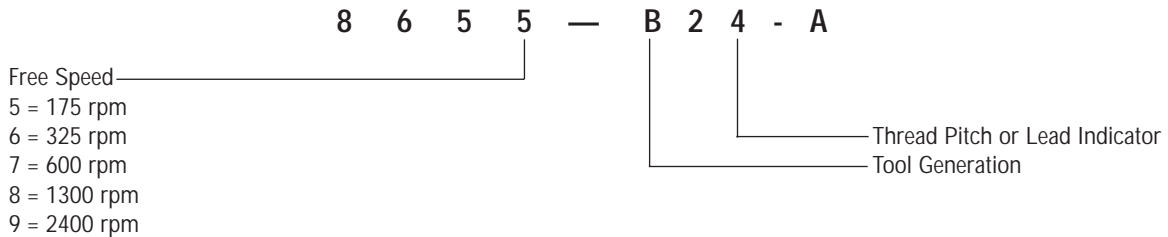

Pneumatic Lead Screw Tappers



SPECIFICATIONS

		NOMINAL TAP CAPACITIES						LEAD SCREW and NUT ASSEMBLY	AIR CONSP.+ @ Working Speed		STD. CHUCK CAPACITY in. (mm)
Steel SAE 1213	3/8" to 1/2" (M10 to M12)	1/4 to 7/16 (M6 to M10)	No. 8 to 1/4 (M4 to M6)	No. 2 to No. 10 (M2 to M5)	No. 2 to No. 8 (M2 to M4)		ft ³ /cycle		(L/cycle)		
Aluminum 2024-T4	7/16 to 5/8 (M10 to M16)	5/16 to 1/2 (M8 to M12)	1/4 to 5/16 (M6 to M8)	No. 2 to 5/16 (M2 to M8)	No. 2 to No. 10 (M2 to M5)						
		MODELS									
Free Speed	175 rpm	325 rpm	600 rpm	1,300 rpm	2,400 rpm						
11	8655-B11-A	8656-B11-A	8657-B11-A	—	—		45453-11				
12	8655-B12-A	8656-B12-A	8657-B12-A	—	—		45453-12				
13	8655-B13-A	8656-B13-A	8657-B13-A	8658-B13-A	—		45453-13				
14	8655-B14-A	8656-B14-A	8657-B14-A	8658-B14-A	—		45453-14				
16	8655-B16-A	8656-B16-A	8657-B16-A	8658-B16-A	—		45453-16				
18	8655-B18-A	8656-B18-A	8657-B18-A	8658-B18-A	—		45453-18				
AMERICAN THREAD	20 8655-B20-A	8656-B20-A	8657-B20-A	8658-B20-A	—		45453-20	3.0	(85)	No. 0 to 1/2" (M4.5 to M12)	
PITCH (T.P.I.)	24 8655-B24-A	8656-B24-A	8657-B24-A	8658-B24-A	8659-B24-A		45453-24				
	27 8655-B27-A	8656-B27-A	8657-B27-A	8658-B27-A	8659-B27-A		45453-27				
	28 8655-B28-A	8656-B28-A	8657-B28-A	8658-B28-A	8659-B28-A		45453-28				
	32 8655-B32-A	8656-B32-A	8657-B32-A	8658-B32-A	8659-B32-A		45453-32				
	36 8655-B36-A	8656-B36-A	8657-B36-A	8658-B36-A	8659-B36-A		45453-36				
	40 8655-B40-A	8656-B40-A	8657-B40-A	8658-B40-A	8659-B40-A		45453-40				
	44 8655-B44-A	8656-B44-A	8657-B44-A	8658-B44-A	8659-B44-A		45453-44				
	48 8655-B48-A	8656-B48-A	8657-B48-A	8658-B48-A	8659-B48-A		45453-48				
	56 8655-B56-A	8656-B56-A	8657-B56-A	8658-B56-A	8659-B56-A		45453-56				
	.40										
	.45										
	.50										
METRIC THREAD	.60										
	.70										
LEAD (mm)	.75										
	.80										
	1.00										
	1.25										
	1.50										

METRIC PITCHES
AVAILABLE
CONSULT FACTORY

Special Tappers available, featuring high duty cycle, twin and multi-spindle heads, and left hand threads. Consult factory.
+Consumption in cubic feet during a typical 6 second cycle time. NOTE: Performance data given at 90 PSI (6.2 bar) air pressure.

AIR INLET	CONTROL PORTS	SPINDLE THREAD	RECOMMENDED HOSE SIZE	RECOMMENDED OPERATING PRESSURE
3/8" NPT female	1/8" NPT female	No. 1 Morse Taper female	1/2" ID	90 PSI (6.2 bar)

STANDARD EQUIPMENT

- 41376 Tap Chuck, No. 0-1/2" (M4.5 - M12) Cap.
- Necessary wrenches

ACCESSORIES AT EXTRA COST

- 44889 Floating Tap Chuck, No. 0-5/8" (M1.6 - M16) Cap.
- 44890-() Collets for 44889 Chuck

44889 Floating Tap Chuck



Provides parallel float up to 0.030" (0.76 mm) to ensure the tap being driven aligns properly with the drilled hole. Order the desired size 44890-() Collet separately from the chart at the right.

AMERICAN HAND TAP SIZE	METRIC HAND TAP SIZE	COLLET ID		COLLET NO.
		in.	mm	
No. 0 - No. 6	M1.6 - M6	.141	3.58	44890-1
No. 8	M4	.168	4.27	44890-2
No. 10	M4.5 - M5	.194	4.93	44890-3
No. 12	—	.220	5.59	44890-4
No. 14 & 1/4"	M6	.255	6.48	44890-5
5/16"	M7 - M8	.318	8.08	44890-6
3/8"	—	.381	9.68	44890-7
7/16"	M10	.323	8.20	44890-8
1/2"	M12	.367	9.32	44890-9
9/16"	M14	.429	10.90	44890-10
5/8"	M16	.480	12.19	44890-11
1/8" S.S. Pipe*	—	.313	7.95	44890-12
1/8" L.S. Pipe*	—	.438	11.12	44890-13

*S.S. = Small Shank, L.S. = Large Shank



DRILL CHUCKS



CAPACITY	THREAD SIZE	CHUCK NO.	BODY LENGTH		*CUTTING TOOL PENETRATION	OUTSIDE DIA.	CHUCK KEY NO.
			Jaws Closed	Jaws Open			
0-1/4" (0-6.4 mm)	1/2-20 R.H.	33906	2.190 (55.6)	1.750 (44.5)	11/16 (17.5)	1.320 (33.5)	30209-K
0-3/8" (0-9.5 mm)	3/8-24 R.H.	47341	2.47 (63)	1.930 (49)	13/16 (20.6)	1.420 (36)	30510-K
0-3/8" (0-9.5 mm)	5/8-16 R.H.	45176	3.060 (78)	2.310 (58.7)	61/64 (24)	1.790 (45.5)	30016-K
0-3/8" (0-9.5 mm)	1/2-20 R.H.	33907	2.500 (63.5)	1.906 (48.4)	13/16 (20.6)	1.437 (36)	30510-K
5/64"-1/2" (2-13 mm)	1/2-20 R.H.	30018	3.090 (78.5)	2.420 (61.5)	1-9/64 (29)	1.790 (45.5)	30016-K
3/16"-3/4" (4.8-19 mm)	5/8-16 R.H.	45177	4.120 (104.6)	3.190 (81)	1-17/32 (39)	2.550 (64.8)	45177-K
5/64"-1/2" (2-13 mm)	#33 Jacobs	46977	3.010 (76.4)	2.51 (63.4)	1-9/64 (29)	1.790 (45.5)	30016-K

* Cutting Tool Penetration in chuck varies with Cutter Shank diameter.

TAPER SHANK ADAPTERS

Taper Shank Adapters provide secure means of driving larger taper shank drills into harder materials. Sizes are available for all ARO Automatic Production Drills as optional equipment at extra cost.



MORSE TAPER	THREAD SIZE	TAPER SHANK ADAPTER NO.	LENGTH	OUTSIDE DIA.	FOR USE ON
1	1/2-20 female	35211	3.5" (89 mm)	1.0 (25.4)	Bant-A-Matic, Par-A-Matic
2	1/2-20 female	31394	4.0" (101.5 mm)	1.0 (25.4)	Super Par-A-Matic, 8660 Hi-Thrust
1	5/8-16 female	46090	4.0" (101.5 mm)	1.05 (26.7)	8670 Hi-Thrust
2	5/8-16 female	46091	4.5" (114 mm)	1.17 (29.7)	8670 Hi-Thrust
1	#33 Jacobs Taper	46987	4.0" (101.5 mm)	1.05 (26.7)	Series 34A, 54C & 74B
2	#33 Jacobs Taper	46986	4.5" (114 mm)	1.17 (29.7)	Series 34A, 54C & 74B

CAPACITY	MOUNTING STYLE	CHUCK NO.	LENGTH		CUTTING TOOL PENETRATION	OUTSIDE DIA.	RUBBER FLEX INSERT
			Min.	Max.			
No. 0—1/4" (M1.6 - M6)	.3675" Dia. (9.3 mm)	31427	2.340 (59.4)	2.510 (63.8)	1.0—1-11/64 (25.4—29.8)	1.070 (27.2)	31437
No. 10—5/16" (M4.5 - M8)	.3675" Dia. (9.3 mm)	31432	2.310 (58.7)	2.520 (64)	1.0—1-11/64 (25.4—29.8)	1.070 (27.2)	31436
No. 0—1/2" (M4.5 - M12)	#2 Jacobs Taper	41374**	2.880 (73.2)	3.130 (79.5)	1-3/32—1-3/8 (27.8—35)	1.460 (37.1)	J440 J443
5/16"—5/8" (M7 - M16)	.3675" Dia. (9.3 mm)	32060	2.860 (72.6)	3.130 (79.5)	1-3/32—1-3/8 (27.8—35)	1.460 (37.1)	32061
5/16"—5/8" (M7 - M16)	#2 Jacobs Taper	32063	2.860 (72.6)	3.130 (79.5)	1-3/32—1-3/8 (27.8—35)	1.460 (37.1)	32061

**41376 Tap Chuck Assembly includes 41374 Chuck and 41375 Arbor.

TAP CHUCKS



TAPPING ATTACHMENT	CAPACITY	RUBBER FLEX INSERTS	MOUNTING THREAD	LENGTH	CUTTING TOOL PENETRATION	OUTSIDE DIA.
38021-4*	No. 0—1/4" (M1.6 - M6)	38036	1/2-20	5.781" (146.8 mm)	1-7/32 (31)	2.750 (69.9)
	1/4"—1/2" (M6 - M12)	38036-1	R.H.			
42123-1**	No. 0—1/4" (M1.6 - M6)	37431-2	1/2-20	4.250" (108 mm)	43/64 (17)	1.890 (48)
		37431-3	R.H.			

*Includes 38020-4 Tapping Head and 38020-4 Torque Arm. **Includes 42106-1 Tapping Head and 37601 Torque Arm. Both attachments also include necessary wrenches.

TAPPING HEAD ATTACHMENT



SERIES 35069-() COLLETS

For use on Series 8660, Par-A-Matic and Super Par-A-Matic Drills.



COLLET NO.	SIZE RANGE in. (mm)	INSERT
35069-1	7/32 - 1/4 (5.5 - 6.4)	35263-1
35069-2	1/4 - 9/32 (6.4 - 7.1)	35263-2
35069-3	9/32 - 5/16 (7.1 - 7.9)	35263-3
35069-4	5/16 - 11/32 (7.9 - 8.7)	35263-4
35069-5	11/32 - 3/8 (8.7 - 9.5)	35263-5
35069-6	3/8 - 13/32 (9.5 - 10.3)	35263-6
35069-7	13/32 - 7/16 (10.3 - 11.1)	35263-7
35069-8	7/16 - 15/32 (11.1 - 11.9)	35263-8
35069-9	15/32 - 1/2 (11.9 - 12.7)	35263-9
35069-10	1/2 - 17/32 (12.7 - 13.5)	35263-10
35069-11	17/32 - 9/16 (13.5 - 14.3)	35263-11

Sub-Assemblies
 • 35070 Body
 • 35263-() Insert

Specifications
 • Length: 3-1/4" (82.5 mm)
 • Thread: 1/2-20 female
 • Outside Dia.: 1-3/4" (44.5 mm)
 • Approx. Tooling Penetration: 1-3/4" (44.5 mm)

SERIES 35074-() COLLETS

For use on Series 8660, Par-A-Matic and Super Par-A-Matic Drills.



COLLET NO.	SIZE RANGE in. (mm)	INSERT
35074-1	7/32 - 1/4 (5.5 - 6.4)	35264-1
35074-2	1/4 - 9/32 (6.4 - 7.1)	35264-2
35074-3	9/32 - 5/16 (7.1 - 7.9)	35264-3
35074-4	5/16 - 11/32 (7.9 - 8.7)	35264-4
35074-5	11/32 - 3/8 (8.7 - 9.5)	35264-5
35074-6	3/8 - 13/32 (9.5 - 10.3)	35264-6
35074-7	13/32 - 7/16 (10.3 - 11.1)	35264-7
35074-8	7/16 - 15/32 (11.1 - 11.9)	35264-8
35074-9	15/32 - 1/2 (11.9 - 12.7)	35264-9
35074-10	1/2 - 17/32 (12.7 - 13.5)	35264-10
35074-11	17/32 - 9/16 (13.5 - 14.3)	35264-11
35074-12	9/16 - 19/32 (14.3 - 15.1)	35264-12
35074-13	19/32 - 5/8 (15.1 - 15.9)	35264-13
35074-14	5/8 - 21/32 (15.9 - 16.6)	35264-14
35074-17	23/32 - 3/4 (18.2 - 19.0)	35264-17

Sub-Assemblies
 • 35075 Body
 • 35264-() Insert

Specifications
 • Length: 3-1/4" (82.5 mm)
 • Thread: 1/2-20 female
 • Outside Dia.: 2-1/32" (51.6 mm)
 • Approx. Tooling Penetration: 1-7/8" (47.6 mm)

SERIES 35079-() COLLETS

For use on Bant-A-Matic, Par-A-Matic and Super Par-A-Matic Drills.



COLLET NO.	SIZE RANGE in. (mm)	INSERT
35079-1	3/32 - 1/8 (2.4 - 3.2)	32968-1
35079-2	1/8 - 5/32 (3.2 - 4.0)	32968-2
35079-3	5/32 - 3/16 (4.0 - 4.8)	32968-3
35079-4	3/16 - 7/32 (4.8 - 5.5)	32968-4
35079-5	7/32 - 1/4 (5.5 - 6.4)	32968-5
35079-6	1/4 - 9/32 (6.4 - 7.1)	32968-6
35079-7	9/32 - 5/16 (7.1 - 7.9)	32968-7
35079-8	5/16 - 11/32 (7.9 - 8.7)	32968-8
35079-9	11/32 - 3/8 (8.7 - 9.5)	32968-9

Sub-Assemblies
 • 35080 Body
 • 32968-() Insert

Specifications
 • Length: 2-11/16" (68.3 mm)
 • Thread: 1/2-20 female
 • Outside Dia.: 1-7/16" (36.5 mm)
 • Approx. Tooling Penetration: 1-3/8" (34.9 mm)

SERIES 39959-() COLLETS

For use on Par-A-Matic Offset Drills.



COLLET NO.	SIZE RANGE in. (mm)	INSERT
39959-2	.094 - .177 (2.4 - 4.5)	37431-2
39959-3	.177 - .256 (4.5 - 6.5)	37431-3

Sub-Assemblies
 • 39958 Body & Nut
 • 37431-() Insert

Specifications
 • Length: 1-15/16" (49.2 mm)
 • Thread: 3/8-24 female
 • Outside Dia.: 3/4" (19 mm)
 • Approx. Tooling Penetration: 1-5/16" (33.3 mm)

SERIES 41758-() COLLETS

For use on Series 8660, Par-A-Matic, Super Par-A-Matic and Bant-A-Matic Drills.



COLLET NO.	SIZE RANGE in. (mm)	INSERT
41758-1	1/64 - 3/64 (.40 - 1.2)	31812-1
41758-2	3/64 - 5/64 (1.2 - 2.0)	31812-2
41758-3	5/64 - 3/32 (2.0 - 2.4)	31812-3
41758-4	3/32 - 1/8 (2.4 - 3.2)	31812-4
41758-5	1/8 - 5/32 (3.2 - 4.0)	31812-5
41758-6	5/32 - 3/16 (4.0 - 4.8)	31812-6
41758-7	3/16 - 7/32 (4.8 - 5.5)	31812-7
41758-8	7/32 - 1/4 (5.5 - 6.4)	31812-8

Sub-Assemblies
 • 41756 Body
 • 32541 Nut
 • 31812-() Insert

Specifications
 • Length: 2-9/16" (65.1 mm)
 • Thread: 1/2-20 female
 • Outside Dia.: 3/4" (19 mm)
 • Approx. Tooling Penetration: 1-5/16" (33.3 mm)

SERIES 46093-() & 48175-() COLLETS

Series 8670 Hi-Thrust Drills use 46093-(). Series 34A, 54C & 74B Electro-Feed Drills use 48175-().



Series 46093



Series 48175

COLLET NO.	SIZE RANGE in. (mm)	INSERT
46093-1	48175-1 7/32 - 1/4 (5.5 - 6.4)	35264-1
46093-2	48175-2 1/4 - 9/32 (6.4 - 7.1)	35264-2
46093-3	48175-3 9/32 - 5/16 (7.1 - 7.9)	35264-3
46093-4	48175-4 5/16 - 11/32 (7.9 - 8.7)	35264-4
46093-5	48175-5 11/32 - 3/8 (8.7 - 9.5)	35264-5
46093-6	48175-6 3/8 - 13/32 (9.5 - 10.3)	35264-6
46093-7	48175-7 13/32 - 7/16 (10.3 - 11.1)	35264-7
46093-8	48175-8 7/16 - 15/32 (11.1 - 11.9)	35264-8
46093-9	48175-9 15/32 - 1/2 (11.9 - 12.7)	35264-9
46093-10	48175-10 1/2 - 17/32 (12.7 - 13.5)	35264-10
46093-11	48175-11 17/32 - 9/16 (13.5 - 14.3)	35264-11
46093-12	48175-12 9/16 - 19/32 (14.3 - 15.1)	35264-12
46093-13	48175-13 19/32 - 5/8 (15.1 - 15.9)	35264-13
46093-14	48175-14 5/8 - 21/32 (15.9 - 16.6)	35264-14
46093-15	48175-15 21/32 - 11/16 (16.6 - 17.4)	35264-15
46093-16	48175-16 11/16 - 23/32 (17.4 - 18.2)	35264-16
46093-17	48175-17 23/32 - 3/4 (18.2 - 19.0)	35264-17

Series 46093 Sub-Assemblies
 • 46093 Body
 • 35264-() Insert

Series 46093 Specifications
 • Length: 3.0" (76.2 mm)
 • Thread: 5/8-16 female
 • Outside Dia.: 1-5/8" (41.3 mm)
 • Approx. Tooling Penetration: 1-7/8" (47.6 mm)

Series 48175 Sub-Assemblies
 • 48091 Body
 • 35264-() Insert

Series 48175 Specifications
 • Length: 3-5/16" (84 mm)
 • Taper: No. 33 Jacobs
 • Outside Dia.: 1-3/4" (44 mm)
 • Approx. Tooling Penetration: 1-7/8" (47.6 mm)

Spindle Accessories



ARO AUTOMATION TOOLS STANDARD TWIN DRILL/TWIN TAP HEADS

For single spindle drills already in operation, ARO Twin Drill Head Attachments can be ordered separately which fit directly to ARO Bant-A-Matic, Par-A-Matic, Super Par-A-Matic, and Series 3 Electro-Feed Drills.

Twin Drill Heads have a 1:1 gear ratio and are rated for 5,000 rpm maximum. Heads come complete with necessary wrenches. Collets must be ordered separately.

5/32" (4.0 mm) Collet Capacity
Model 46394
 for Bant-A-Matic Drills

1/4" (6.5 mm) Collet Capacity
Model 46023
 for Par-A-Matic Drills
Model 47489
 for Super Par-A-Matic Drills

3/8" (9.5 mm) Collet Capacity
Model 46063
 for Super Par-A-Matic Drills
Model 47276
 for Series 34A, 54C & 74B
 Electro-Feed Drills

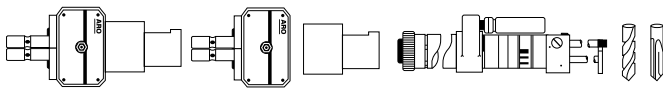

Complete Head Ass'y.	Head Only Ass'y.	Adapter Ass'y.	Used On	Used For	Adj. Spindle Center Distances, in.		Series Part No.	Collet Bore, in.		Max. Tap Size
					Min.	Max.		Min.	Max.	
46394	48057-1	48056-1	Bant-A-Matic	Drilling	.375	2.125	47368-(-)	.039	.157	
48060-1	48057-1	48058-1	Bant-A-Matic	Tapping	.375	2.125	47368-(-)			#6
46023	47980	47283	Par-A-Matic	Drilling	.500	2.500	45998-(-)	.039	.256	
48055	47980	47982	Par-A-Matic	Tapping	.500	2.500	45998-(-)			1/4"
46063	47768	47767	S. Par-A-Matic	Drilling	.750	3.750	46033-(-)	.079	.375	
47288	47768	47282	S. Par-A-Matic	Tapping	.750	3.750	46033-(-)			5/16"
47489	47980	47490	S. Par-A-Matic	Drilling	.500	2.500	45998-(-)	.039	.256	
47276	47768	47876	Series 34A, 54C, 74B	Drilling	.750	3.750	46033-(-)	.079	.375	
47908	47768	47907	Series 34A, 54C, 74B	Tapping	.750	3.750	46033-(-)			5/16"
48061-1	48057-1	48059-1	Lead Screw Tapper	Tapping	.375	2.125	47368-(-)			#6
48054	47980	47981	Lead Screw Tapper	Tapping	.500	2.500	45998-(-)			1/4"
47277	47768	47785	Lead Screw Tapper	Tapping	.750	3.750	46033-(-)			5/16"

NOTE: Drill bits should always be operated in drill bushings for proper support and alignment.



ARO MULTI-SPINDLE DRILLING/TAPPING HEADS

In addition to the Twin Spindle drill and tapping heads shown on page 26, there are several other configurations available. Each

configuration is offered in a head size (type) that matches the size and duty of a particular self-feed tool.

TWIN SPINDLE EXTRA REACH ADJUSTABLE

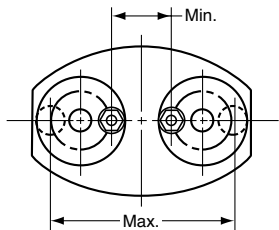

TYPE	MAX.	DRILL	CENTERS		USED WITH	COLLETS USED
			MIN.	MAX.		
400	5/32	(4.0)	.750 (19.0)	2.500 (63.5)	A	47368 - ()
650	1/4	(6.5)	1.000 (12.7)	3.000 (76.2)	B, F, G.	45998 - ()
950	3/8	(9.5)	1.500 (38.1)	4.500 (114.3)	C, D, E, F, G.	46033 - ()

THREE SPINDLE IN LINE ADJUSTABLE

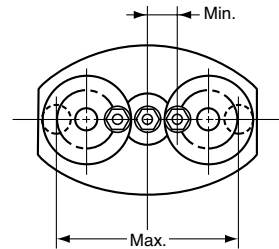

TYPE	MAX.	DRILL	CENTERS		USED WITH	COLLETS USED
			MIN.	MAX.		
400	5/32	(4.0)	.375 (9.5)	1.250 (31.7)	A	47368 - ()
650	1/4	(6.5)	.500 (12.7)	1.500 (38.1)	B, F, G.	45998 - ()
950	3/8	(9.5)	.750 (19.0)	2.250 (57.1)	C, D, E, F, G.	46033 - ()

THREE SPINDLE ADJUSTABLE

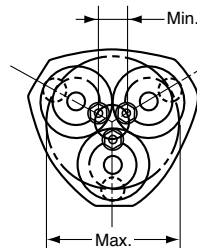

TYPE	MAX.	DRILL	CENTERS		USED WITH	COLLETS USED
			MIN.	MAX.		
400	5/32	(4.0)	.565 (14.3)	2.320 (58.9)	A	47368 - ()
650	1/4	(6.5)	.735 (18.7)	2.730 (69.3)	B, F, G.	45998 - ()
950	3/8	(9.5)	1.100 (27.9)	4.100 (104.1)	C, D, E, F, G.	46033 - ()

FOUR SPINDLE ADJUSTABLE

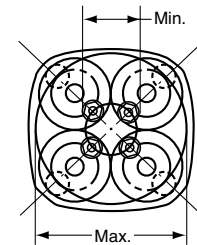

TYPE	MAX.	DRILL	CENTERS		USED WITH	COLLETS USED
			MIN.	MAX.		
400	5/32	(4.0)	.890 (22.6)	2.645 (67.2)	A	47368 - ()
650	1/4	(6.5)	1.125 (28.6)	3.120 (79.2)	B, F, G.	45998 - ()
950	3/8	(9.5)	1.680 (42.7)	4.680 (118.9)	C, D, E, F, G.	46033 - ()

FIXED CENTER NON-ADJUSTABLE

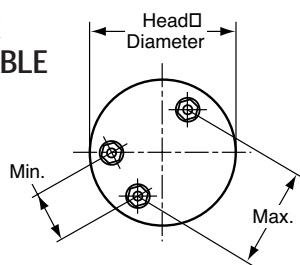

TYPE	MAX.	DRILL	CENTERS		USED WITH	COLLETS USED
			MIN.	MAX.		
400	5/32	(4.0)	.375 (9.5)	2.125 (54.0)	A	47368 - ()
650	1/4	(6.5)	.500 (12.7)	2.500 (63.5)	B, F, G.	45998 - ()
950	3/8	(9.5)	.750 (19.0)	3.750 (95.0)	C, D, E, F, G.	46033 - ()

()=mm

USED WITH: A=Bant-A-Matic B=Par-A-Matic C=Super Par-A-Matic D=8660 E=8670
F=FE034A G=FE054C H=FE074A

For assistance with application, dimensions, price and delivery - consult factory.

Spindle Accessories



TWIN DRILL COLLETS

BORE Dia. ⁺⁰⁰⁰ / ₋₀₀₃₅	DRILL SIZES		46394 HEAD (Bant-A-Matic)	46023 HEAD (Par-A-Matic) 47489 Head	46063/47276 HEAD (Super Par-A-Matic) Series 34A, 54C, 74A Electra-Feed	BORE Dia. ⁺⁰⁰⁰ / ₋₀₀₃₅	DRILL SIZES		46023 HEAD (Par-A-Matic) 47489 Head	46063/47276 HEAD (Super Par-A-Matic) Series 34A, 54C, 74A Electra-Feed	
	inch	no. mm					inch	no. mm			
.039"	61	1.0	47368-1	45998-1		.209"	4	5.3	45998-44	46033-34	
.043"	57	1.1	47368-2	45998-2		.213"	3	5.4	45998-45	46033-35	
.047"	3/64	56	47368-3	45998-3		.216"	—	5.5	45998-46	46033-36	
.052"	55	1.3	47368-4	45998-4		.220"	7/32	2	5.6	45998-47	46033-37
.055"	54	1.4	47368-5	45998-5		.224"	—	5.7	45998-48	46033-38	
.059"	53	1.5	47368-6	45998-6		.228"	1	5.8	45998-49	46033-39	
.063"	1/16	52	47368-7	45998-7		.232"	—	5.9	45998-50	46033-40	
.067"	51	1.7	47368-8	45998-8		.236"	15/64	A	6.0	45998-51	46033-41
.071"	50	1.8	47368-9	45998-9		.240"	B	6.1	45998-52	46033-42	
.075"	48	1.9	47368-10	45998-10		.244"	C	6.2	45998-53	46033-43	
.079"	5/64	47	47368-11	45998-11	46033-1	.248"	D	6.3	45998-54	46033-44	
.083"	45	2.1	47368-12	45998-12	46033-2	.252"	1/4	E	6.4	45998-55	46033-45
.087"	44	2.2	47368-13	45998-13	46033-3	.256"	F	6.5	45998-56	46033-46	
.091"	43	2.3	47368-14	45998-14	46033-4	.260"	G	6.6		46033-47	
.094"	3/32	42	47368-15	45998-15	46033-5	.264"	17/64	—	6.7	46033-48	
.098"	40	2.5	47368-16	45998-16	46033-6	.268"	H	6.8		46033-49	
.102"	38	2.6	47368-17	45998-17	46033-7	.272"	I	6.9		46033-50	
.106"	36	2.7	47368-18	45998-18	46033-8	.276"	J	7.0		46033-51	
.110"	7/64	35	47368-19	45998-19	46033-9	.280"	9/32	K	7.1	46033-52	
.114"	33	2.9	47368-20	45998-20	46033-10	.283"	—	7.2		46033-53	
.118"	32	3.0	47368-21	45998-21	46033-11	.287"	—	7.3		46033-54	
.122"	31	3.1	47368-22	45998-22	46033-12	.291"	L	7.4		46033-55	
.126"	1/8	—	47368-23	45998-23	46033-13	.295"	M	7.5		46033-56	
.130"	30	3.3	47368-24	45998-24	46033-14	.299"	19/64	—	7.6	46033-57	
.134"	29	3.4	47368-25	45998-25	46033-15	.303"	N	7.7		46033-58	
.138"	—	3.5	47368-26	45998-26	46033-16	.307"	—	7.8		46033-59	
.142"	9/64	28	47368-27	45998-27	46033-17	.311"	5/16	—	7.9	46033-60	
.146"	26	3.7	47368-28	45998-28	46033-18	.315"	O	8.0		46033-61	
.150"	25	3.8	47368-29	45998-29	46033-19	.319"	—	8.1		46033-62	
.154"	23	3.9	47368-30	45998-30	46033-20	.323"	P	8.2		46033-63	
.157"	5/32	22	47368-31	45998-31	46033-21	.327"	21/64	—	8.3	46033-64	
.161"	20	4.1		45998-32	46033-22	.331"	Q	8.4		46033-65	
.165"	19	4.2		45998-33	46033-23	.335"	—	8.5		46033-66	
.169"	18	4.3		45998-34	46033-24	.339"	R	8.6		46033-67	
.173"	11/64	17		45998-35	46033-25	.342"	11/32	—	8.7	46033-68	
.177"	16	4.5		45998-36	46033-26	.346"	—	8.8		46033-69	
.181"	14	4.6		45998-37	48033-27	.350"	S	8.9		46033-70	
.185"	13	4.7		45998-38	46033-28	.354"	—	9.0		46033-71	
.189"	3/16	12		45998-39	46033-29	.358"	23/64	T	9.1	46033-72	
.193"	10	4.9		45998-40	46033-30	.362"	—	9.2		46033-73	
.197"	9	5.0		45998-41	46033-31	.366"	—	9.3		46033-74	
.201"	7	5.1		45998-42	46033-32	.370"	U	9.4		46033-75	
.205"	13/64	5		45998-43	46033-33	.375"	3/8	—	9.5	46033-76	

TWIN TAP COLLETS

TAPPING HEAD NUMBER	#0-#6	#8	#10	#12	1/4"	5/16"
48060-1						
48061-1	47368-27	NA	NA	NA	NA	NA
48054						
48055	45998-27	45998-34	45998-41	45998-47	45998-56	NA
47277, 47288, 47908	46033-17	46033-24	46033-31	46033-37	46033-46	46033-62



HYDRAULIC CHECK UNITS



For added tool versatility and performance, Hydraulic Check Units can be used to **provide positive feed rate or breakthrough control**. Units are available in 1", 2" and 3" stroke lengths for all electric and pneumatic ARO Automatic Feed Tools. They are easily installed and **never need to be refilled**. Other benefits include —

- allows rapid advance to the workpiece to minimize cycle time
- fully adjustable settings to achieve optimum chip size
- helps prevent drill bit breakage, drill stalling and heavy burrs

Hydraulic checks are standard equipment on all Hi-Thrust Series Drills, and are available at extra cost for all Bant-A-Matic, Par-A-Matic, Super Par-A-Matic Drills and all Series 34A, 54C and 74B Electra Feed Drills.

TOOL SERIES	1.0" (25 mm)	STROKE	2.0" (51 mm)	STROKE	3.0" (76 mm)	STROKE	MOUNTING BRACKET Only	CHECK DIAMETER in. (mm)	OVERALL LENGTH		
	Hydraulic Check Ass'y*	Check Only	Hydraulic Check Ass'y*	Check Only	Hydraulic Check Ass'y*	Check Only			1.0" Stroke	2.0" Stroke	3.0" Stroke
Bant-A-Matic	40301-2	38922	40301-3	38922-1	40301-4	38922-2	40298				
Par-A-Matic	40591-3	38922	40591-4	38922-1	40591-5	38922-2	40316				
Super Par-A-Matic	40591-3	38922	40591-4	38922-1	40591-5	38922-2	40316				
Series 34A, 54C, & 74B Electra Feed		38922		38922-1		38922-2		15/16 (24)	7-7/8 (200)	10-7/8 (276)	13-7/8(352)
8670 Hi-Thrust	—	38922	—	38922-1	—	38922-2	44910				

*Hydraulic Check Assemblies come complete with check and mounting bracket.

ELECTRONIC INTERFACE KIT

120 VACKit No. 80183395
 24 VDCKit No. 80183395

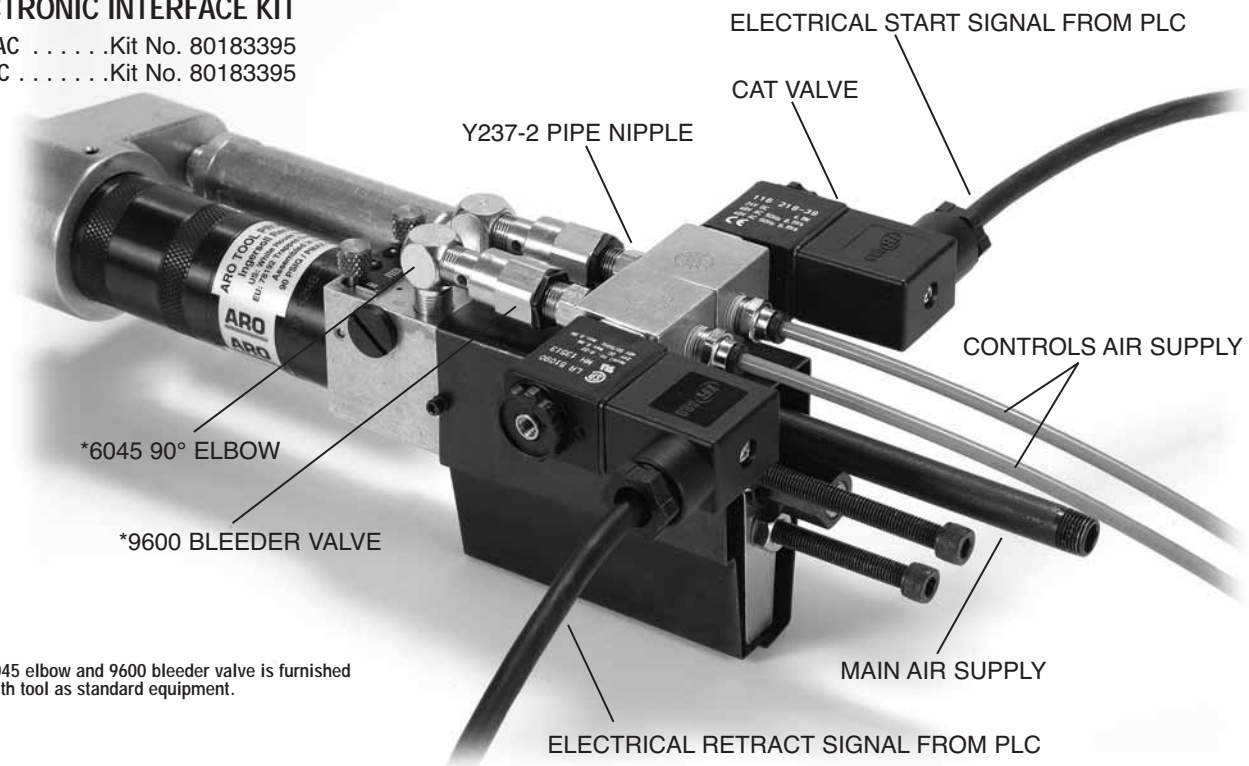

* 6045 elbow and 9600 bleeder valve is furnished with tool as standard equipment.



41729 DWELL CONTROL KIT

The 41729 Dwell Control Kit is a complete, easily installed control accessory for pneumatic and electric ARO Automatic Feed Drills. It provides an adjustable, precisely timed pause, or dwell, at the end of the forward stroke. The range of the dwell interval, prior to retraction, is from .10 to 10 seconds.

Depth control for ARO Automatic Feed Drills is achieved through the use of a positive-stop adjustment screw. The addition of the dwell control is desirable for countersinking and cleanup applications.

The 41729 Dwell Control Kit may be used on any of the drill models listed in the chart.

	TOOL SERIES		
	Bant-A-Matic	Par-A-Matic	Super Par-A-Matic
Models	8245	8255	8265
Models	8248	8258	8268
Models		8266	



41730 AUXILIARY CONTROL KIT

The 41730 Auxiliary Control Kit provides increased flexibility to pneumatic and electric ARO Automatic Feed Tools in designing automated machining systems. It can be used to generate a cycle completion signal, for example, or any other desired auxiliary signal.

Each kit is furnished with a miniature, three-way limit valve having a short roller lever and instant tube fittings. Additional limit valves can be installed for other functions.

The 41730 Auxiliary Control Kit may be used on any of the tool models listed in the chart.

	TOOL SERIES		
	Bant-A-Matic	Par-A-Matic	Super Par-A-Matic
Models	8245	8255	8265
Models	8246	8256	8268
Models	8248	8257	
Models		8258	
Models		8266	

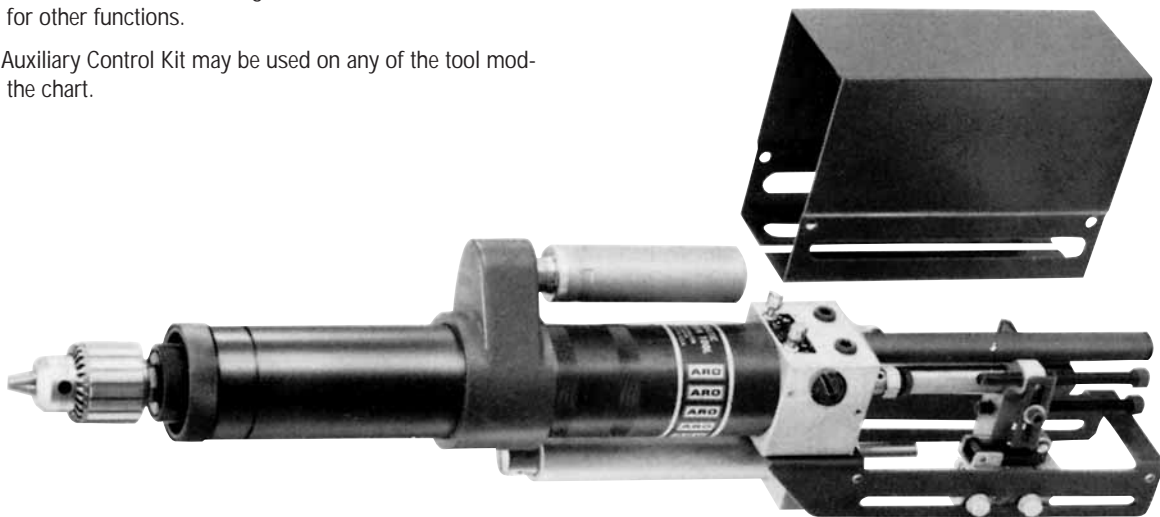

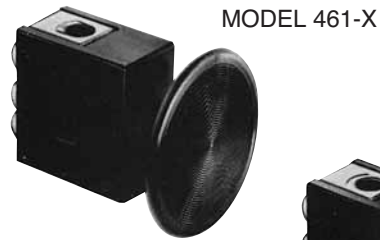

MODEL 461-X
w/20975 Guard



460 SERIES PALM BUTTON CONTROL VALVES

APPLICATION INFORMATION

- Valves are 2-position, 3-way, manually actuated with spring return. Each valve can be plumbed to perform “normally open,” “normally closed,” “selector,” or any 2-way function.
- Use as operator controls to START tools or START cycle, or to EMERGENCY RETRACT tools, etc.
- Available in 1/8" NPT(F) ports and with 5/32" instant tube fittings.
- Equipped with 2 1/2" (63.5 mm) buttons in four colors.
- Design permits panel or side mounting.
- Optional full guard available.

To order, select the model number for port size and button color. Order P/N20975 Guard separately if required.

SPECIFICATIONS

VALVE MODELS w/Instant Tube Fittings	VALVE MODELS w/1/8" NPT(F) Ports	BUTTON COLOR
461-1	460-1	Black
461-2	460-2	Red
461-3	460-3	Green
461-4	460-4	Yellow

OPERATING PRESSURE30 to 150 PSIG (2.1 to 10.4 bar)
 TEMPERATURE RANGE32° to 160°F (0° to 71°C)
 FLOW CAPACITY4.0 SCFM (1.9 dm³/s) with instant tube fittings;
 7.5 SCFM (3.6 dm³/s) with 1/8" NPT(F) ports.
 ACTUATING FORCE4 lbs. (17.8 N) at 100 PSIG (7 bar) inlet.

APPLICATION EXAMPLE

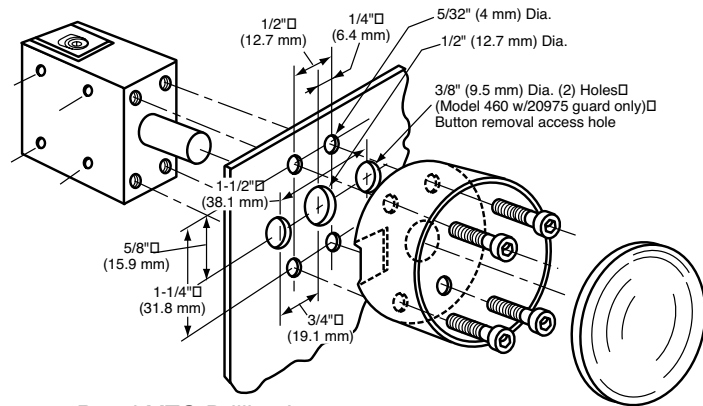
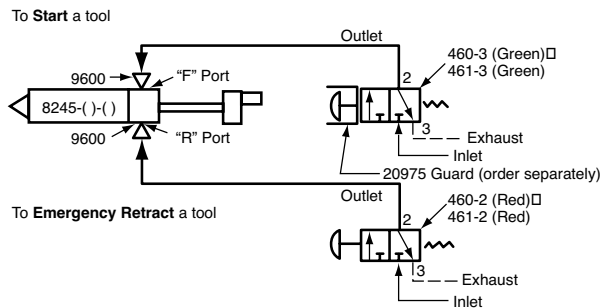

Panel MTG Drilling Layout

DIMENSIONS & MOUNTING

MODEL 461-X

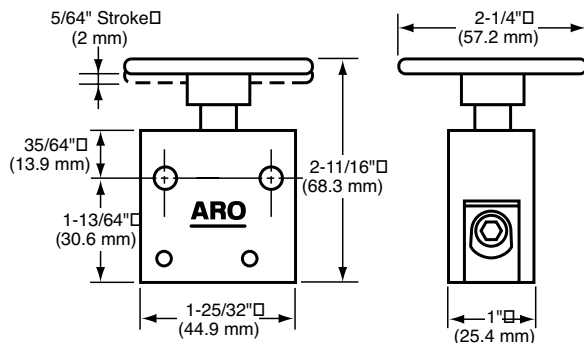

MODEL 461-X w/20975 Guard

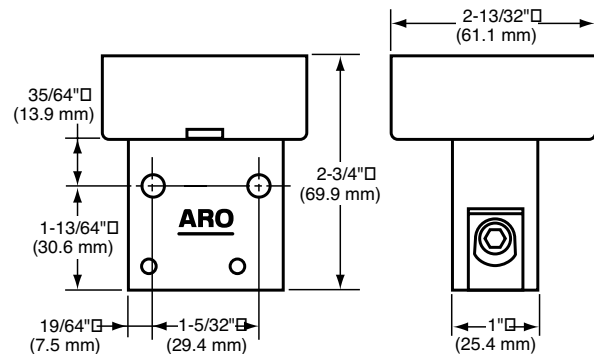

WARNING: Inappropriate or improper use, application, installation, service or maintenance of ARO Valves may create a hazardous or dangerous condition or situation. Please refer to the warning and cautions described in the ARO Pneumatic Valves Catalog or in the ARO Pneumatic Logic Controls Catalog. Consult your ARO distributor or representative for specific details.

The Circuit Accessories shown on pages 31 thru 38 are those elements most often used to control and interlock self-feed tools. A greater range of pneumatic valves and accessory components may be found in the ARO Pneumatic Valves Catalog and the ARO Pneumatic Logic Controls Catalog.



400 SERIES 3-WAY LIMIT VALVES

- Valve can be plumbed to perform as “normally open,” “normally closed,” “selector,” or any 2-way valve function.
- Four actuator styles available.
- Lever action may be selected as clockwise, counterclockwise, or both directions.
- Operating head may be adjusted to any of four positions.
- Outer case seals working parts against dirt and damage.
- Available with instant tube fittings for use with 5/32" (4 mm) nylon tubing, or 1/8" NPT(F) ports.

To order, specify valve model and actuator type separately.

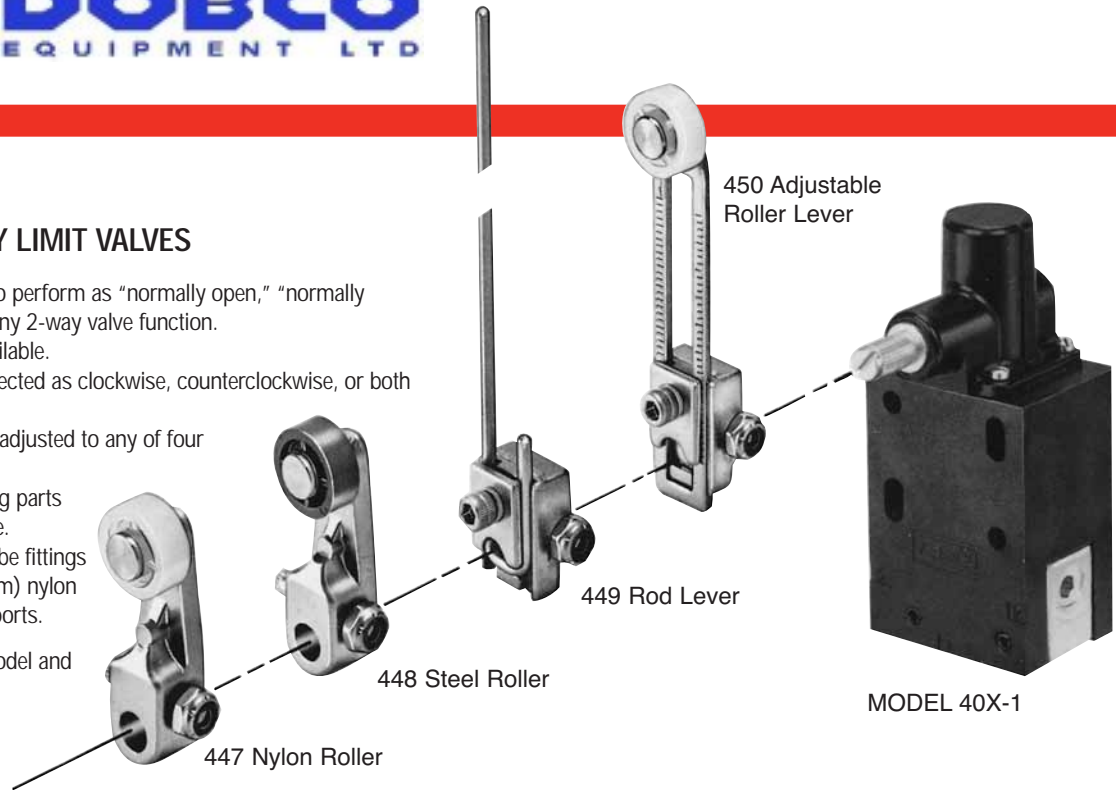

SPECIFICATIONS

VALVE MODELS w/Instant Tube Fittings	VALVE MODELS w/1/8" NPT(F) Ports	VALVE ACTION
400-1	400	One way, clockwise
401-1	401	One way, counterclockwise
402-1	402	Clockwise & counterclockwise

OPERATING PRESSURE 30 to 150 PSIG (2.1 to 10.4 bar)
 TEMPERATURE RANGE -32° to 160°F (0° to 71°C)
 FLOW CAPACITY 3.0 SCFM (1.9 dm³/s) with instant tube fittings;
 7.5 SCFM (3.6 dm³/s) with 1/8" NPT(F) ports.
 ACTUATING FORCE 1.5 lb.in. (.02 Nm)

DIMENSIONS

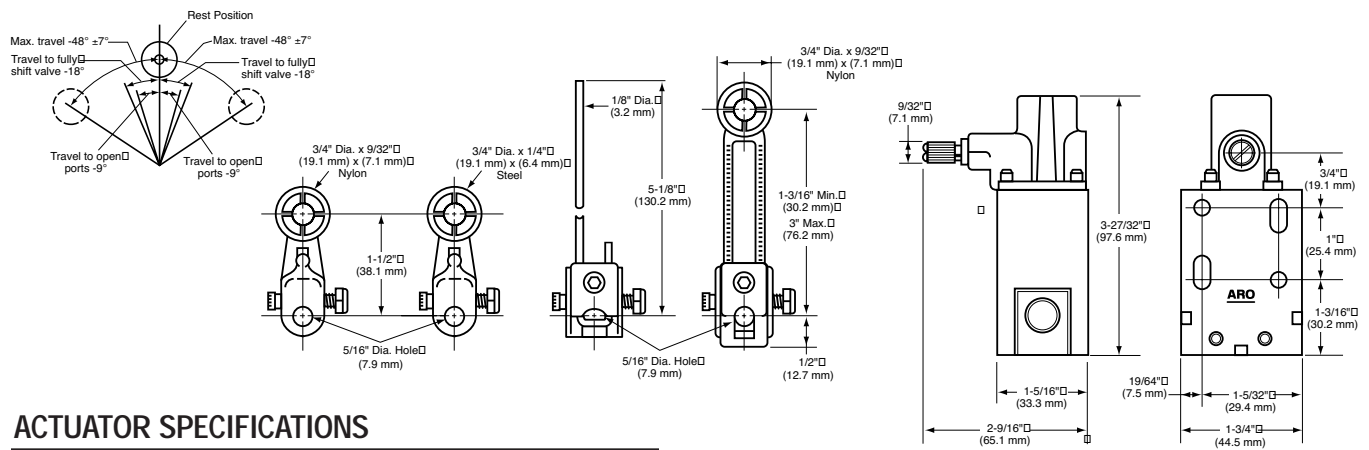

ACTUATOR SPECIFICATIONS

ACTUATOR MODEL	LEVER TYPE	FORCES REQUIRED ON LEVER TO ACTUATE VALVE
447	Nylon Roller	1.0 lb. (4.4 N)
448	Steel Roller	1.0 lb. (4.4 N)
449	Rod Lever	0.3 lb. (1.3 N)
450	Adj. Roller Lever	0.5 lb. (2.2 N) (At minimum length)

WARNING: Inappropriate or improper use, application, installation, service or maintenance of ARO Valves may create a hazardous or dangerous condition or situation. Please refer to the warning and cautions described in the ARO Pneumatic Valves Catalog or in the ARO Pneumatic Logic Controls Catalog. Consult your ARO distributor or representative for specific details.



MODEL 206-2-C 3-WAY MINIATURE VALVE

APPLICATION INFORMATION

- A low cost two-position, pilot-actuated valve with spring return.
- Use for CYCLE COMPLETION for Lead Screw Tappers and tools with piston rod access (use "In N.O." for this).
- Can be plumbed to perform as "normally open," "normally closed," or as a diverter valve.
- Pilot actuator has a low friction U-cup seal on piston.
- Equipped with 5/32" instant tube fittings.
- Mounting holes are standard 1.0" electrical centers.



Model 206-2-C

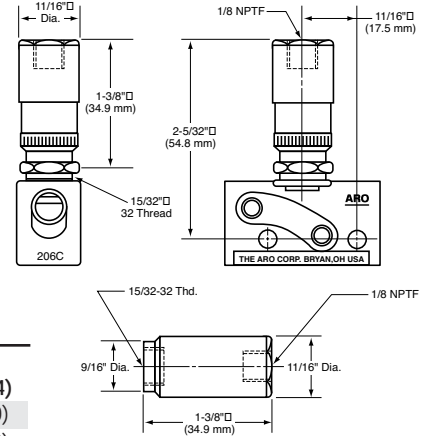

SUPPLY PRESSURE	MIN. PILOT PRESSURE PSIG (bar)					
	25 (1.7)	50 (3.5)	75 (5.2)	100 (6.9)	125 (8.6)	150 (10.4)
Piped IN — N.N.P.	11.5 (0.8)	12.0 (0.8)	12.5 (.9)	13.0 (0.9)	13.5 (0.9)	14.0 (1.0)
Piped IN — N.P.	14.5 (1.0)	17.0 (1.2)	19.5 (1.3)	22.0 (1.5)	24.5 (1.7)	27.0 (1.9)

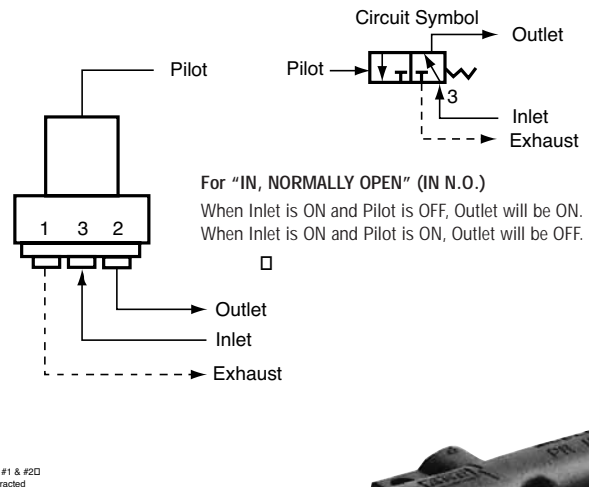
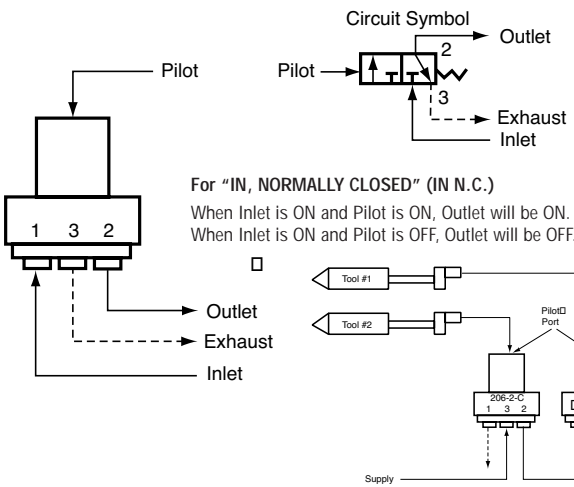

MODEL PR10 SINGLE PULSE RELAY VALVE

APPLICATION INFORMATION

- Converts a continuous air signal into a single air pulse according to supply pressure used (see chart at right).
- Use to actuate a single device requiring momentary signals—from a limit valve supplying a continuous signal.
- Output turns ON when Input turns ON.
- Output turns OFF when preset time is reached (see chart at right).
- Removing Input resets valve for next cycle (see chart at right).
- Flow path indicated by arrow on valve body.
- Has a minimum pulse pressure of 35 PSIG (2.4 bar) and an operating range of 35 to 150 PSIG (2.4 to 10.4 bar).
- 1/8" NPT ports, inlet and outlet.

NOTE: For best results, outlet of the PR10 should be close to inlet port of next device. Use care not to overtighten fittings in plastic body.

WARNING: Inappropriate or improper use, application, installation, service or maintenance of ARO Valves may create a hazardous or dangerous condition or situation. Please refer to the warning and cautions described in the ARO Pneumatic Valves Catalog or in the ARO Pneumatic Logic Controls Catalog. Consult your ARO distributor or representative for specific details.

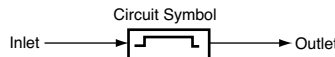

Model PR10

SUPPLY PSIG PRESSURE (bar)	PULSE DURATION ms	RESET TIME ms
50 (3.5)	125	160
75 (5.2)	110	170
100 (6.9)	105	180
125 (8.6)	100	190

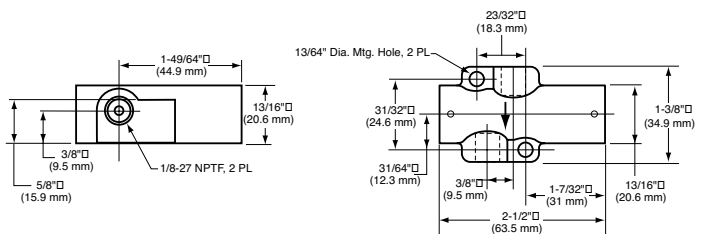



Model 201-2-C

DIMENSIONS

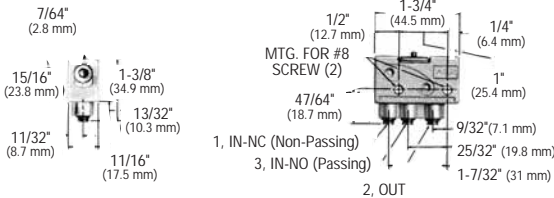

200 SERIES MINIATURE 3-WAY LIMIT VALVES

APPLICATION INFORMATION

- Ideal for sensing position of moving machine devices, such as cylinders, slides, gates, etc.
- Valve can be plumbed to perform as "normally open," "normally closed," or any 2-way function.
- Fifteen actuator styles available—five manual and ten mechanical.
- Equipped with 5/32" instant tube fittings.
- Valves have zinc die cast body and stainless steel spool with Viton O-Ring Dynamic Seals / Buna-N Static Seals.

To order, specify the desired model number shown below.

ACCESSORIES

Stacking Kits contain all components (except valves) and instructions necessary for assembly. Valves must be ordered separately. Specify model number of kit according to the number of valves to be stacked.

KIT NO.	QUANTITY OF VALVES				
	2	3	4	5	6
225-2	225-3	225-4	225-5	225-6	

SPECIFICATIONS

OPERATING PRESSURE30 to 150 PSIG (2 to 10 bar)
TEMPERATURE RANGE32° to 160° F (0° to 71° C)
FLOW CAPACITY4.0 SCFM (1.9 dm ³ /s)
ACTUATING FORCE Forces listed below are for valve installed in "closed" mode. For forces in "open" mode, add 40%.

<p>MODEL 200-2-C PLAIN LEVER</p> <p>Actuation: Force – 20 oz. (5.6 N) Stroke – .195" (5.0 mm) Overtravel – .055" (1.4 mm) Weight – 3.5 oz. (99 g)</p>	<p>MODEL 201-2-C FINGERTIP LEVER</p> <p>Actuation: Force – 20 oz. (5.6 N) Stroke – .289" (7.3 mm) Overtravel – .086" (2.2 mm) Weight – 4 oz. (113 g)</p>	<p>MODEL 202-2-C SHORT ROLLER LEVER</p> <p>Actuation: Force – 36 oz. (10.0 N) Stroke – .086" (2.2 mm) Overtravel – .024" (0.6 mm) Weight – 3.5 oz. (99 g)</p>
<p>MODEL 203-2-C LONGER ROLLER LEVER</p> <p>Actuation: Force – 21 oz. (5.8 N) Stroke – .086" (2.2 mm) Overtravel – .024" (0.4 mm) Weight – 3.5 oz. (99 g)</p>	<p>MODEL 204-2-C ONE WAY, SHORT LEVER</p> <p>Actuation: Force – 34 oz. (9.5 N) Stroke – .089" (2.3 mm) Overtravel – .027" (0.7 mm) Weight – 4 oz. (113 g)</p>	<p>MODEL 205-2-C ONE WAY, LONG LEVER</p> <p>Actuation: Force – 23 oz. (6.4 N) Stroke – .164" (4.2 mm) Overtravel – .024" (0.6 mm) Weight – 4 oz. (113 g)</p>
<p>MODEL 209-2-C PIN PLUNGER</p> <p>Actuation: Force – 57 oz. (15.8 N) Stroke – .062" (1.6 mm) Overtravel – .015" (0.4 mm) Weight – 3 oz. (85 g)</p>	<p>MODEL 212-2-C BALL ROLLER, SHORT</p> <p>Actuation: Force – 57 oz. (15.8 N) Stroke – .062" (1.6 mm) Overtravel – .015" (0.4 mm) Weight – 3.5 oz. (99 g)</p>	<p>MODEL 213-2-C BALL ROLLER, LONG</p> <p>Actuation: Force – 57 oz. (15.8 N) Stroke – .062" (1.6 mm) Overtravel – .015" (0.4 mm) Weight – 3.5 oz. (99 g)</p>
<p>MODEL 214-2-C STRAIGHT PLUNGER</p> <p>Actuation: Force – 57 oz. (15.8 N) Stroke – .062" (1.6 mm) Overtravel – .089" (2.3 mm) Weight – 3.5 oz. (99 g)</p>	<p>MODEL 215-2-C ROLLER PLUNGER</p> <p>Actuation: Force – 57 oz. (15.8 N) Stroke – .062" (1.6 mm) Overtravel – .089" (2.3 mm) Weight – 4 oz. (113 g)</p>	<p>MODEL 216-2-C CROSS-ROLLER PLUNGER</p> <p>Actuation: Force – 57 oz. (15.8 N) Stroke – .062" (1.6 mm) Overtravel – .089" (2.3 mm) Weight – 4 oz. (113 g)</p>
<p>MODEL 223-2-C RETAINED TOGGLE</p> <p>Actuation: Force – 24 oz. (6.7 N) Stroke – 70° Weight – 3.5 oz. (99 g)</p>	<p>MODEL 222-2-C CENTERING TOGGLE</p> <p>Actuation: Force – 24 oz. (6.7 N) Stroke – 70° Weight – 3.5 oz. (99 g)</p>	<p>MODEL 224-2-C PANEL BUTTON</p> <p>Actuation: Force – 57 oz. (15.4 N) Stroke – .062" (1.6 mm) Overtravel – .015" (0.4 mm) Weight – 4 oz. (113 g)</p>

WARNING: Inappropriate or improper use, application, installation, service or maintenance of ARO Valves may create a hazardous or dangerous condition or situation. Please refer to the warning and cautions

described in the ARO Pneumatic Valves Catalog or in the ARO Pneumatic Logic Controls Catalog. Consult your ARO distributor or representative for specific details.



MODEL 59157 ADJUSTABLE, SINGLE-PULSE RELAY VALVE

APPLICATION INFORMATION

- Converts a continuous air signal into a single air pulse of adjustable duration ranging from 0.8 to 7.5 seconds.
- Use to actuate feed tools or devices requiring momentary signals from a limit valve supplying a continuous signal.
- Output turns ON when Input turns ON.
- Output turns OFF when adjusted time is reached.
- Removing Input resets valve for next cycle.
- 1/8" NPT(F) ports.

SPECIFICATIONS

OPERATING PRESSURE30 to 150 PSIG (2 to 10 bar)
 TEMPERATURE RANGE32° to 160°F (0° to 71°C)
 DIMENSIONS1 1/4" x 1 1/8" x 3 3/8" high (32 x 48 x 85 mm)
 MOUNTING HOLES(2) 3/16" Dia. thru base in opposite corners of a 7/8" x 1 9/16" (22 x 40 mm) rectangular pattern.

Model 59157

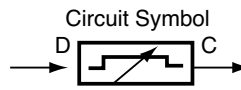

"E" SERIES 3-WAY & 4-WAY PILOT VALVES

APPLICATION INFORMATION, 4-WAY VALVE—MODEL E212PD DOUBLE PILOT ACUATED, MODEL E212PS PILOT ACUATED SPRING RETURN

- Use to power double-acting cylinders up to 2.5" piston diameter.
- Use to power reversible air motors thru 0.5 HP. Motor always runs either forward or reverse rotation. Combine with 3-way valve for ON/OFF function, or choose a three position valve.
- Valves are two-position.
- 1/4" NPT(F) power air ports and 1/8" NPT(F) pilot ports for remote control.

3-WAY VALVE—MODEL E252PD DOUBLE PILOT ACUATED, MODEL E252PS PILOT ACUATED SPRING RETURN

- Use to power single-acting (spring return) cylinders up to 2.5" piston diameter.
- Use to power single-direction air motors thru 0.5 HP (ON/OFF function).

SPECIFICATIONS

OPERATING PRESSURE20 to 200 PSIG (1.4 to 13.8 bar)
 Minimum pilot pressure—15 PSIG (1.0 bar)
 TEMPERATURE RANGE-10° to 180°F (-23° to 82°C)
 FLOW CAPACITY26 SCFM (12 dm³/s)

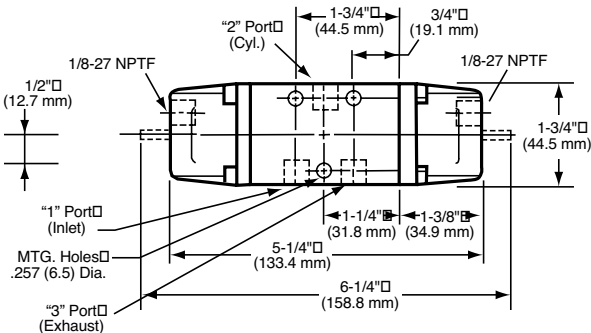
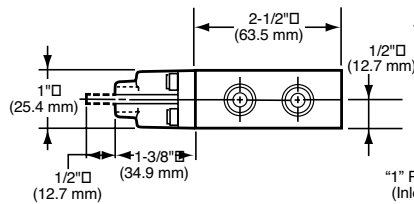
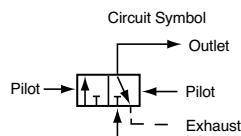

E252PS
E252PD

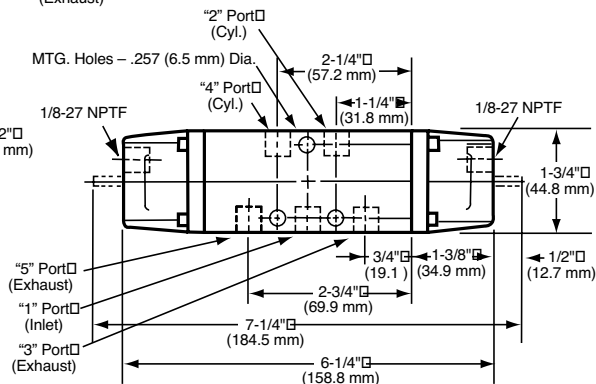
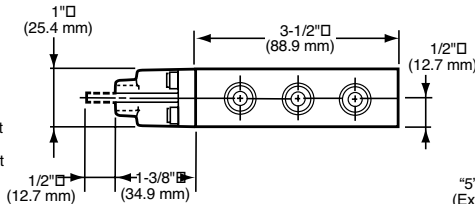
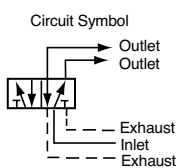

E212PS
E212PD

WARNING: Inappropriate or improper use, application, installation, service or maintenance of ARO Valves may create a hazardous or dangerous condition or situation. Please refer to the warning and cautions

described in the ARO Pneumatic Valves Catalog or in the ARO Pneumatic Logic Controls Catalog. Consult your ARO distributor or representative for specific details.



TWO-HAND ANTI-TIE-DOWN CONTROL PACKAGES

- Ideal for machines where position of operator's hands must be monitored.
- Actuate and hold both air valve buttons concurrently to maintain an output air signal. If either push button is released, the output air signal is exhausted, indicating the operator's hands are no longer in position.
- Operating Pressures: 50-125 PSI (3.5-8.6 bar). Designed to comply with OSHA regulations.

Warning: These provide only the anti-tie down logic function and are not stroke limiting devices. On machines with full revolution clutches and/or where repeat cycles can occur, approved safety and/or single stroke devices must be used in conjunction with the anti-tie down units.

Elements

59191 Base Mounted

- Element has three 1/8" NPTF ports on top. 2 inputs, 1 output.
- Element is base mounted.

Ordering Information: Order push button valves separately.



59191

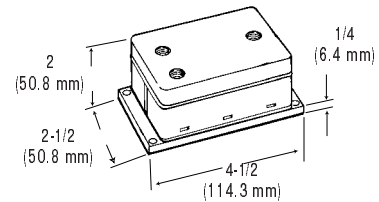

Packages

59808

- Includes two enclosures with green push button valves separated by a length of flexible conduit. External supply and output to machine is made by 5/32" (4mm) instant tube fittings.
- Comes assembled with all internal connections ready to install on machine.
- Palm Buttons are 30" center to center.



59808

59809

- Green push buttons located on opposite ends of a single enclosure. External supply and output to machine is made by 5/32" (4mm) instant tube fittings.
- Comes assembled with all internal connections ready to install on machine.

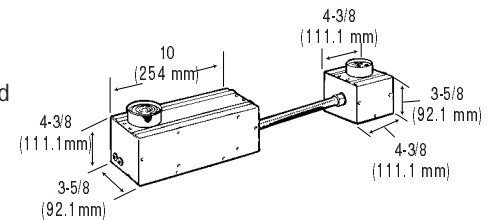

59003-842

- Unassembled package.
- Includes 59191 anti-tie-down block, two 461-3 palm buttons with 20975 guards, 10 feet of 5/32" tubing and fittings for 59191.
- Customer can custom fit components to machine.

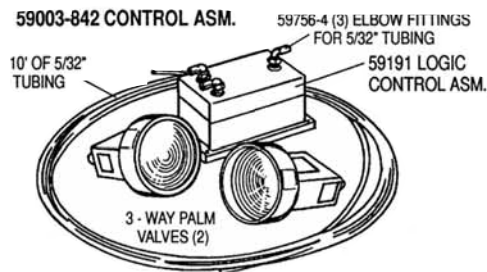

59809

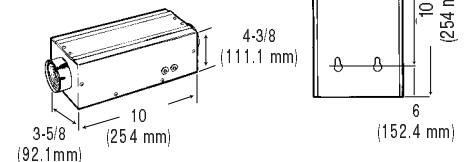

Model 37750



MODEL 37750 TERMINAL MANIFOLD

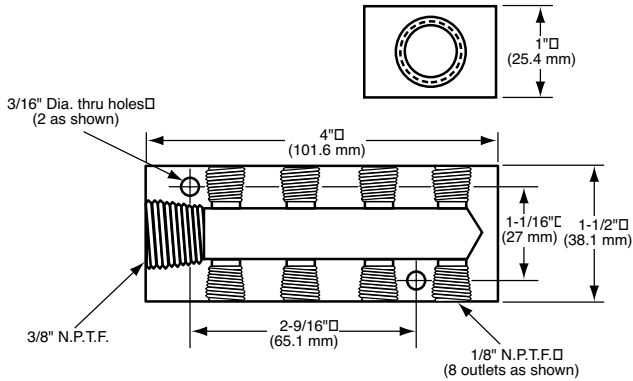

APPLICATION EXAMPLE

To start several self-feed tools with one signal—

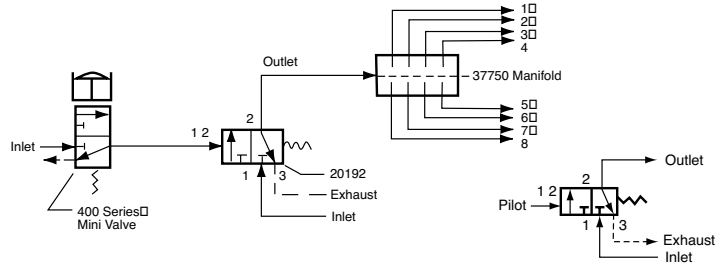

APPLICATION INFORMATION

- Eight station distribution manifold for control circuit signals.
- One 3/8" NPT(F) supply port and eight 1/8" NPT(F) signal ports.

NOTE: Mounting screws not included.

Tubeing, Fittings & Connectors

Y-Connector	Tube Size
59482	5/32

Male Connector	Tube Size	NPT
59474-4	5/32	1/8
59474-56	1/4	1/8
59474-156	1/4	1/4
59474-256	1/4	3/8



Union	Tube Size
59759-4	5/32
59759-56	1/4



Union Elbow	Tube Size
59760-4	5/32
59760-56	1/4



Tubeing (100' rolls)	Tube Size
59690-4	5/32



Union Tee	Tube Size
59761-4	5/32
59761-56	1/4



Male Elbow	Tube Size	NPT
59756-103	5/32	#10-32
59756-4	5/32	1/8
59756-56	1/4	1/8
59756-156	1/4	1/4



Union Bulkhead	Tube Size
59762-4	5/32
59762-56	1/4



Male Branch Tee	Tube Size	NPT
59757-4	5/32	1/8
59757-56	1/4	1/8
59757-156	1/4	1/4



Expander Tube Male	Tube Size	NPT
59765-4	5/32	1/4



Reducer Tube Male	Tube Size	NPT
59765-56	1/4	5/32

Plug	Tube Size
59763-4	5/32
59763-56	1/4



Maximum Working Pressure Vacuum to 250 PSI (17 bar)
Temperature Range - +5°F to 160°F (-15°F to 71°C)
Tubing Material: Nylon II



INLINE "AND" & "OR" CIRCUIT COMPONENTS

APPLICATION INFORMATION

- Miniature, low cost elements to provide "AND" and "OR" functions in pneumatic control circuitry.
- Require #10-32 male connector for each of three ports.

MODEL 59914 "OR"

The ARO Model 59914 "OR" function (shuttle) connects two air signals to a common output. Either input, when applied, flows directly to the output port. An internal poppet prevents a loss of pressure from the input not in use. The 59914 "OR" function can replace many small metal shuttles and logic elements presently in use. It is lightweight, corrosion-resistant and easy to install.

It can be used to allow additional input of a signal into a circuit.

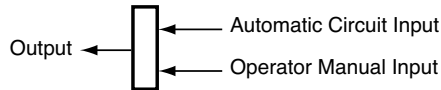
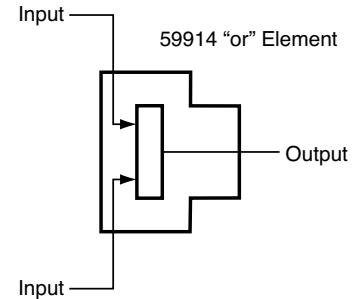
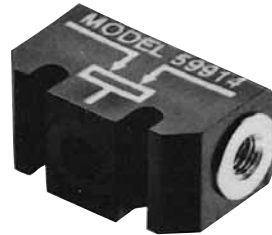

MODEL 59913 "AND"

The ARO Model 59913 "AND" function also connects two air signals to a common output. Both input signals must be ON to create an output signal. A loss of pressure at either input will cause the output to go OFF. The 59913 "AND" function is used to interlock two signals for sequence or safety. It can replace larger pilot-operated valves and logic elements previously used for this purpose. It is lightweight, corrosion-resistant and easy to install.

It can be used to sum signals to achieve an action after all signals are present.

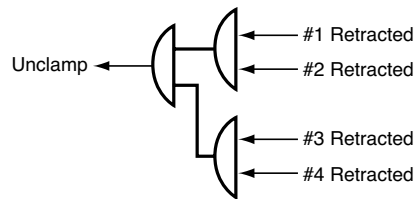
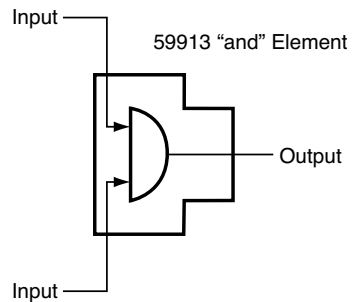
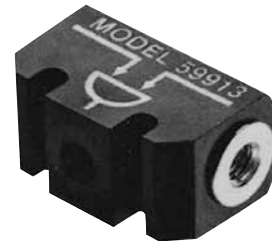

EXAMPLE: Unclamp a part when all tools are retracted.

DIMENSIONS

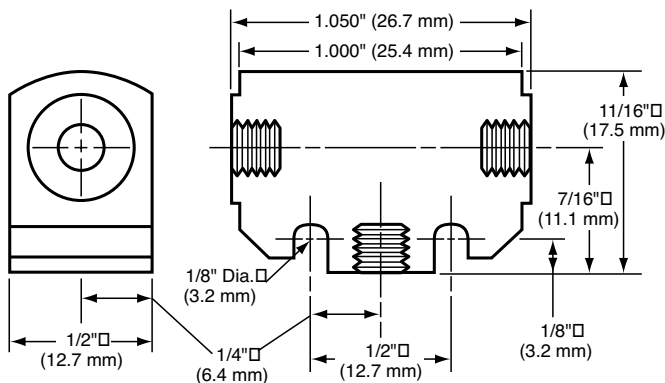

SPECIFICATIONS

OPERATING PRESSURE30 to 150 PSIG (2 to 10 bar)
TEMPERATURE RANGE32° to 160°F (0° to 71°C)
FLOW CAPACITY *	"OR" = 4.0 SCFM (1.9 dm ³ /s)
		"AND" = 3.2 SCFM (1.5 dm ³ /s)
PORTS	#10-32 Female Thread
BODY MATERIALAcetal Resin
INSERTS	Aluminum
SHUTTLE/POPPET	Buna-N
		*90 PSIG (6.2 bar) supply, 75 PSIG (5.2 bar) outlet.

WARNING: Inappropriate or improper use, application, installation, service or maintenance of ARO Valves may create a hazardous or dangerous condition or situation. Please refer to the warning and cautions described in the ARO Pneumatic Valves Catalog or in the ARO Pneumatic Logic Controls Catalog. Consult your ARO distributor or representative for specific details.



To complement its comprehensive line of automatic production tools, ARO offers a variety of mounting options to meet countless fixture requirements. The availability of a wide assortment of standard mounting components provides the user with three important benefits:

PRECISION. All clamping devices are designed specifically for ARO Automatic Production Tools to provide rigid mounting.

VERSATILITY. ARO mounting components permit ARO Automatic Production Tools to be positioned vertically, horizontally, or at 3-dimensional angles in relation to the workpiece. They are also suitable for clamping other machine elements.

LOW COST. Standard components for mounting tools minimize the need to construct special holding or clamping devices. This results in low jigging costs, easier service and higher reuse value.

To select and order the proper mounting components, please consider the following—

1. Identify the particular series of tool to be used, i.e., Bant-A-Matic, Par-A-Matic, etc.
2. From all the possible mounting options for ARO Automatic Production Tools illustrated below, note those available for the series tool to be used.
3. Keeping in mind the attitude of the tool to the workpiece and the amount of space in which the mount must fit, select the best available mounting accessory for the application from pages 39-46 (dimensions are shown for each mount).

NOTE: When selecting either stationary or portable nose mounting, pay particular attention to thread sizes and drill ranges.

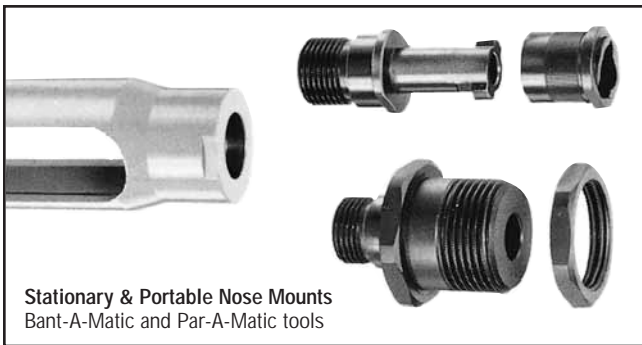

Stationary & Portable Nose Mounts
Bant-A-Matic and Par-A-Matic tools



Stationary & Portable Nose Mounts
Super Par-A-Matic and Hi-Thrust tools

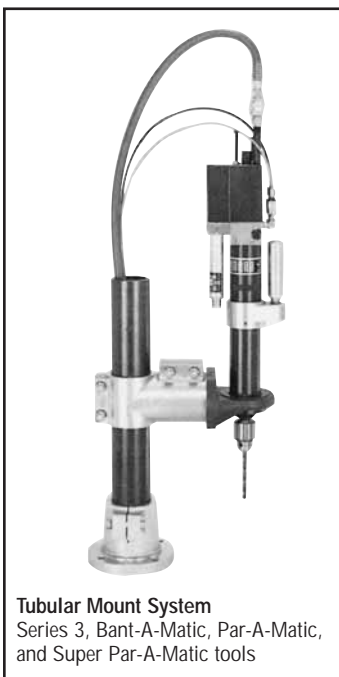

Tubular Mount System
Series 3, Bant-A-Matic, Par-A-Matic,
and Super Par-A-Matic tools



Flange Bracket
Bant-A-Matic, Par-A-Matic, and
Super Par-A-Matic tools

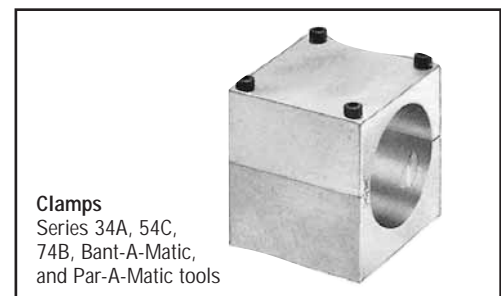

Clamps
Series 34A, 54C,
74B, Bant-A-Matic,
and Par-A-Matic tools



Standard & Heavy-Duty
Foot Brackets
Bant-A-Matic,
Par-A-Matic, and
Super Par-A-Matic,
and Hi-Thrust tools

SERIES 34A & 54C (Mounting Clamps and Riser)

Mounting Clamp Assembly 49690

Mounts feed drill securely to flat surfaces. May be bolted in place from top or from bottom. Uses keys for alignment. Includes 3/8 x 1/8 in. keys.

Riser 49771

Provides necessary elevation for installations where the feed drill must clear the mounting plane. Bolts under 49690 clamp, and bolts down to mount surface.

MOUNTING ARRANGEMENTS

49690 CLAMP ASSEMBLY

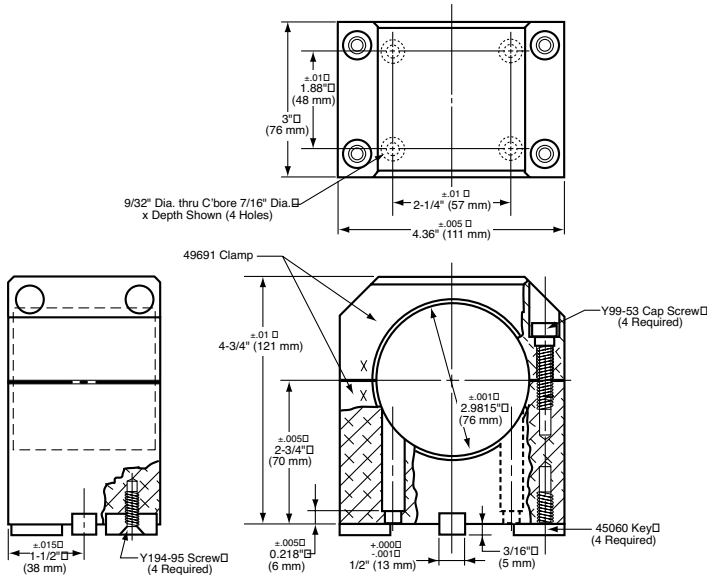

49771 RISER BLOCK KIT

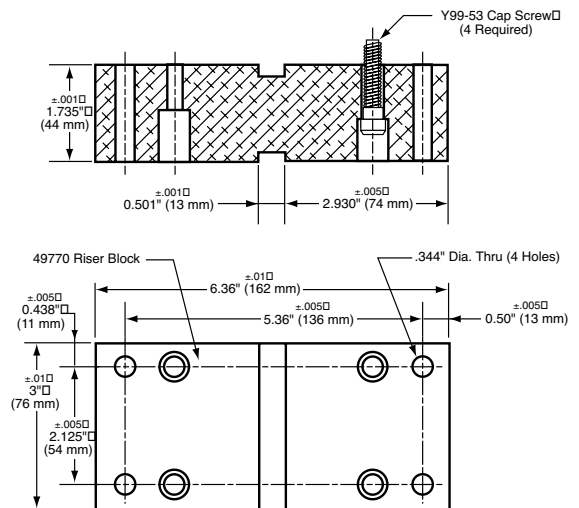

46982-1 CLAMP ASSEMBLY

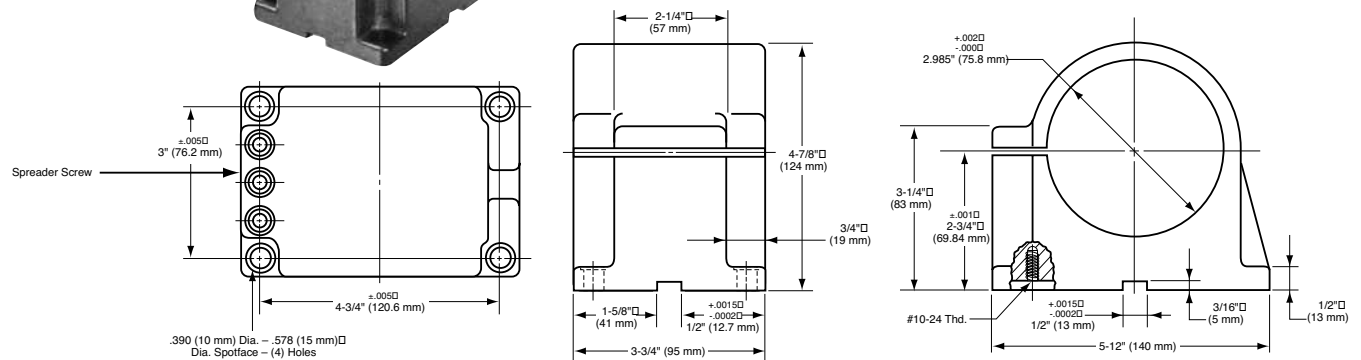



BANT-A-MATIC SERIES



Flange Bracket
P/N 39486
(Includes Nut)

39476 Nut 1-7/16" - 18 L.H. Thread

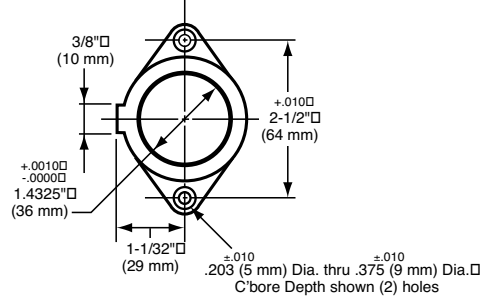
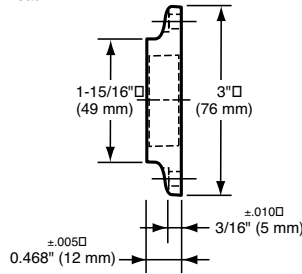
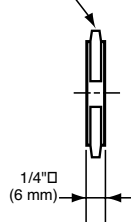

Standard-duty
Foot Bracket
P/N 39485-1
(Includes Nut)

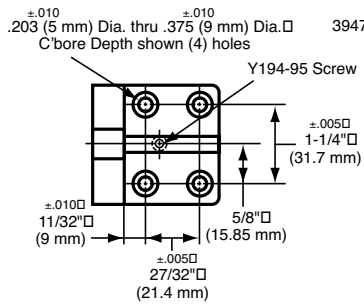

39476 Nut 1-7/16" - 18 L.H. Thread

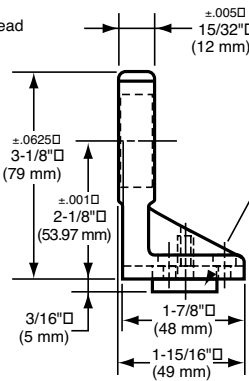
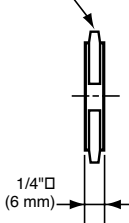

45060 Key

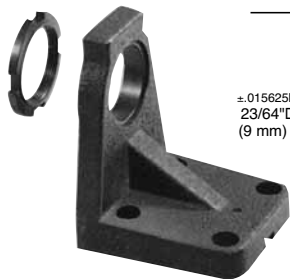
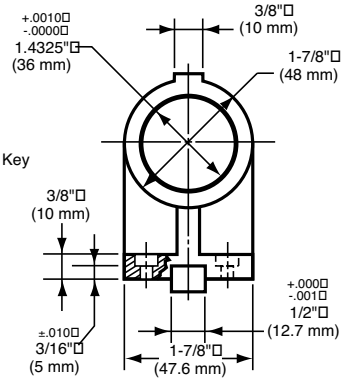

Heavy-duty
Foot Bracket
P/N 45053
(Includes Nut)

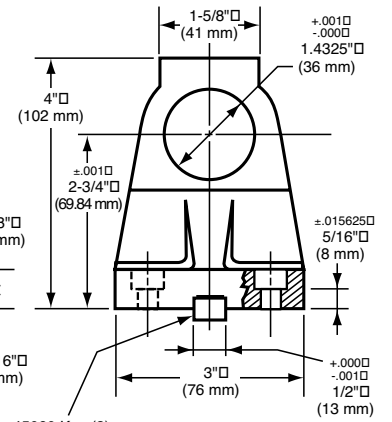
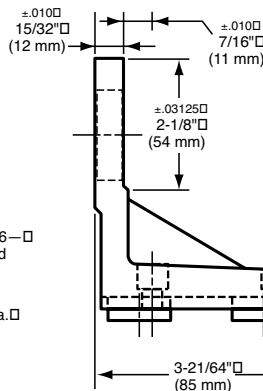
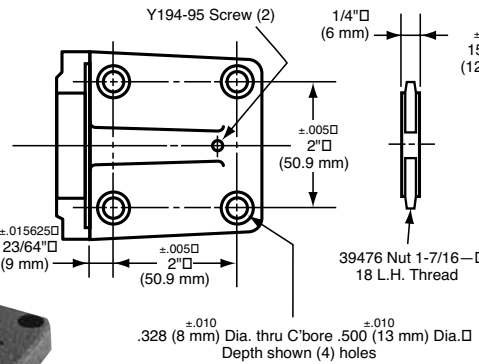

45060 Key (2)



Block Clamp
P/N 36042

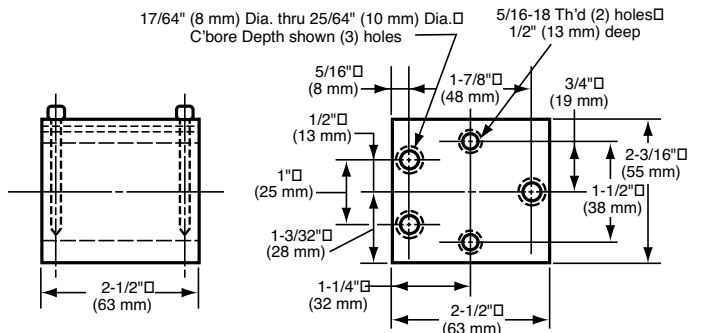
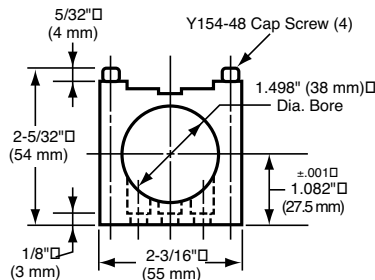

PAR-A-MATIC SERIES



Flange Bracket
P/N 38877
(Includes Nut & Ring)

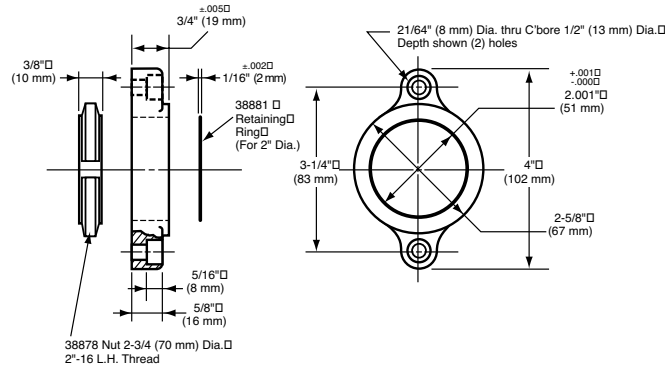

Standard-duty
Foot Bracket
P/N 38875-1
(Includes Nut & Ring)

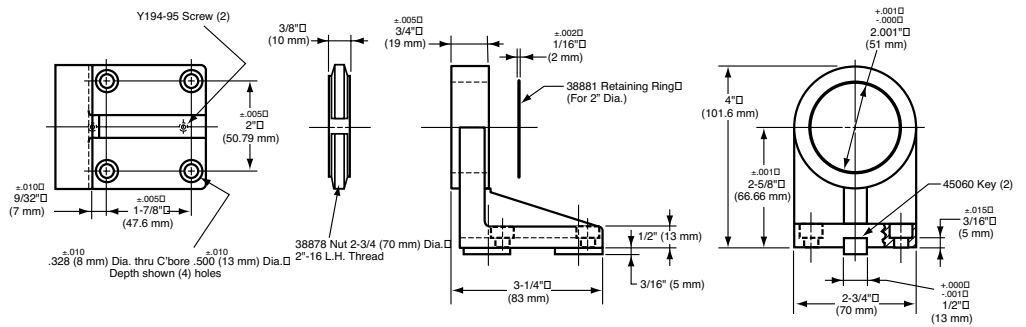

Heavy-duty
Foot Bracket
P/N 45055
(Includes Nut & Ring)

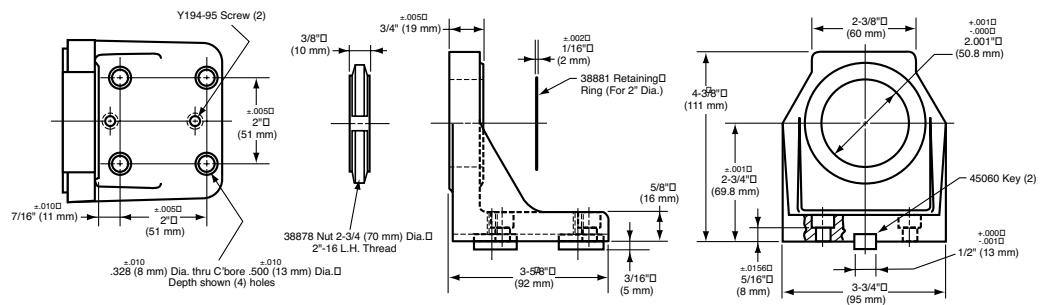

Block Clamp
P/N 35283

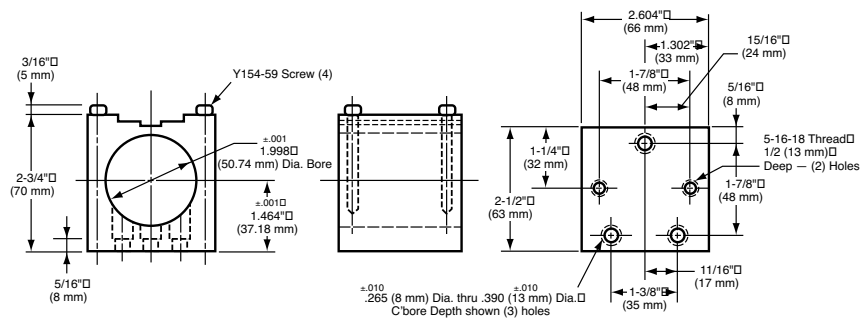



SUPER-PAR-A-MATIC SERIES



Flange Bracket
P/N 40589
(Includes Nut & Ring)

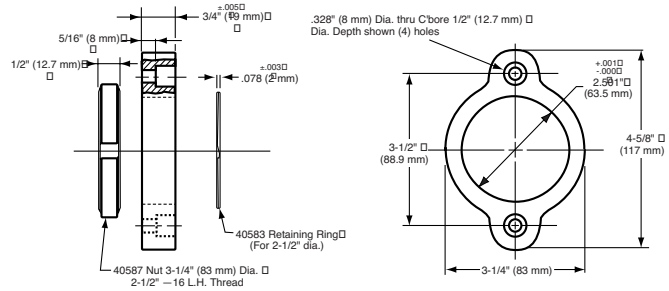

Standard-duty Foot Bracket
P/N 40588-1
(Includes Nut & Ring)

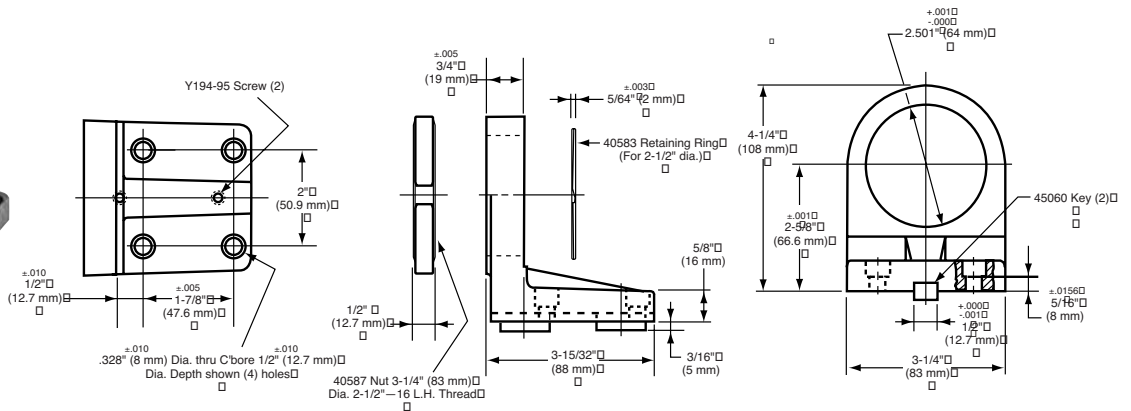

Heavy-duty Foot Bracket
P/N 45056
(Includes Nut & Ring)

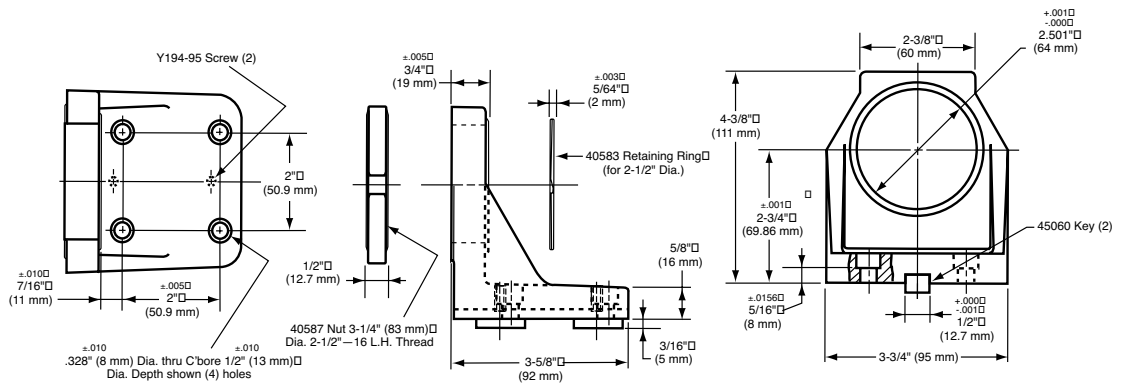

Collet-type Foot Bracket
P/N 41454

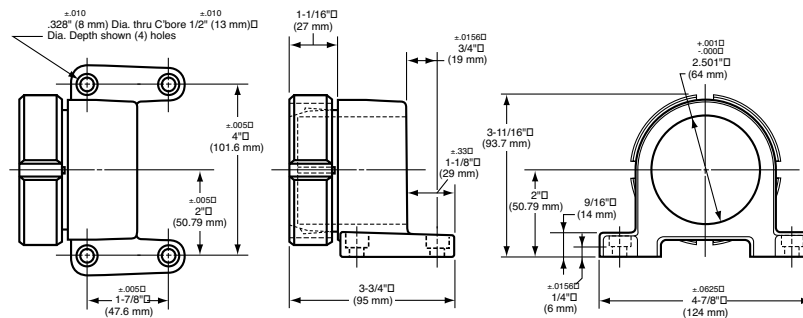

HI-THRUST 8670 SERIES



Heavy-duty
Foot Bracket
P/N 45185
(Includes Nut)

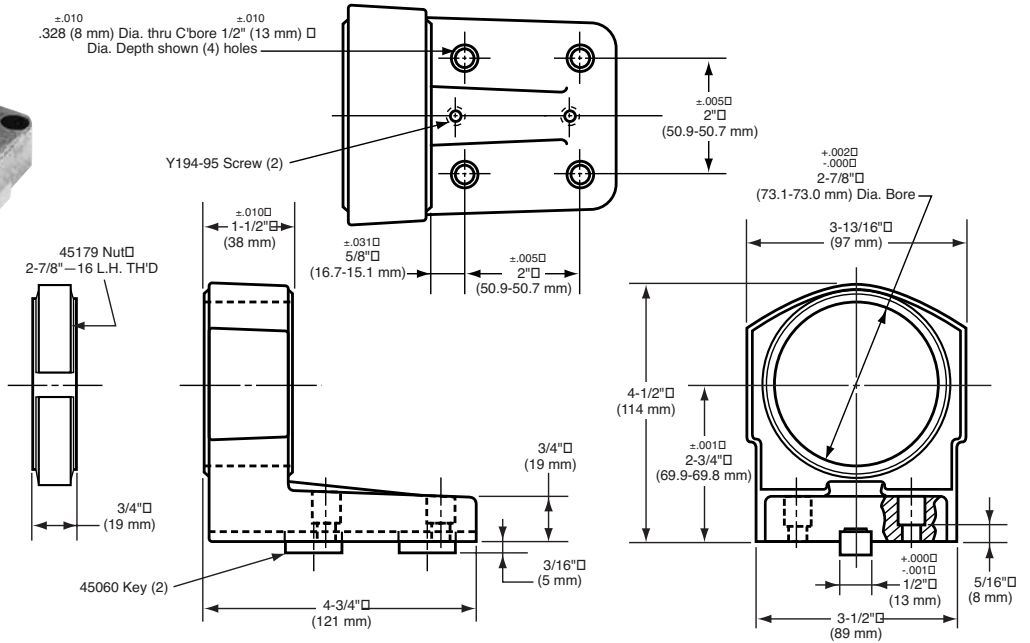



TUBULAR MOUNTING SYSTEM



The ARO Tubular Mounting System is an extremely versatile method of mounting ARO Bant-A-Matic, Par-A-Matic, and Super Par-A-Matic Series tools. Available mounting components accommodate endless fixture requirements and permit the positioning of tools at virtually any angle to the workpiece.

The following illustrations show just a few examples of the many fixture possibilities.

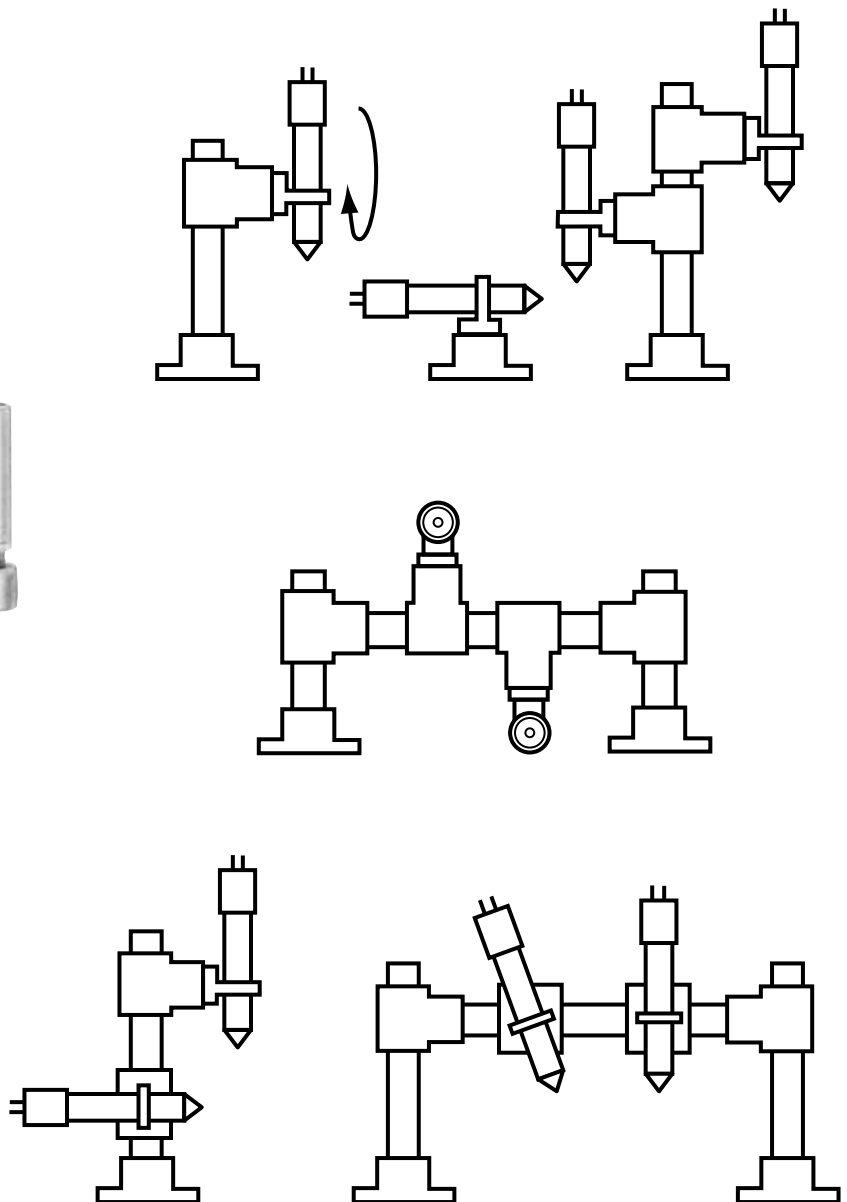

43788 Base Mount Assembly

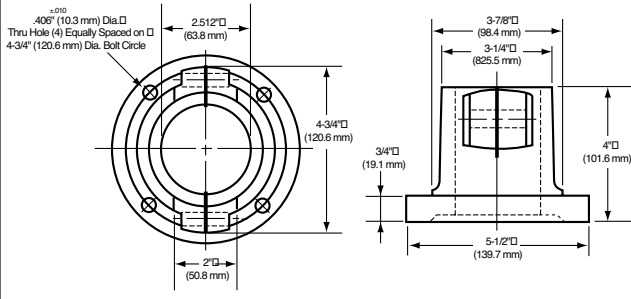
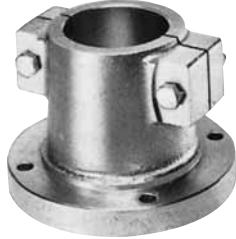

43791-() Mounting Tube

MOUNTING TUBE*	LENGTH "L"
43791-6	6.0" (152 mm)
43791-12	12.0" (305 mm)
43791-18	18.0" (457 mm)
43791-24	24.0" (610 mm)
43791-30	30.0" (762 mm)

*Longer tubes available upon request.

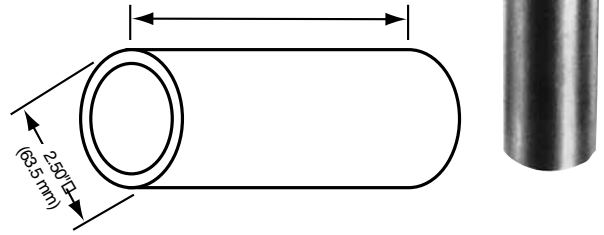

43790 Tee Mount

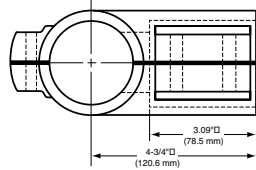

43790 Tee Mount

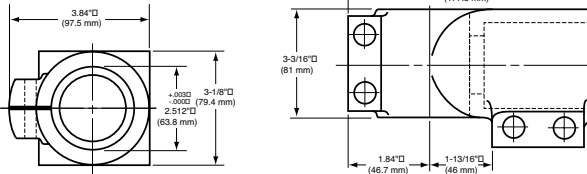

Designed to connect a Tool Mount Assembly to a Mounting Tube. Forms a right angle from the mounting tube.

43786-() Tool Mount Assembly



Designed to hold ARO Bant-A-Matic, Par-A-Matic and Super Par-A-Matic Series tools. Tool Mount Assemblies come complete with a mounting bracket, lock nut and retaining ring.

TOOL SERIES	TOOL MOUNT ASSEMBLY	MOUNTING BRACKET	LOCK NUT	RETAINING RING	DIAMETER "D"
Bant-A-Matic	43786-1	43785-1	39476	None	1.432" (36.4 mm)
Par-A-Matic	43786-2	43785-2	38878	38881	2.001" (50.8 mm)
Super Par-A-Matic	43786-3	43785-3	40587	40583	2.501" (63.5 mm)

04333860 Tool Mount

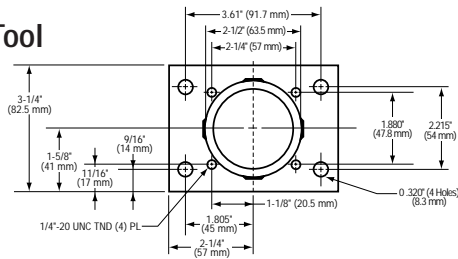

Accepts 49690 Clamp (for FE034A, FE054C & FE074B)

Adapts electric/pneumatic tools to tubular mounts.

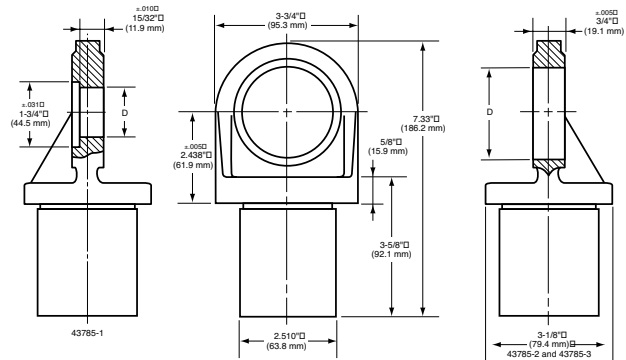
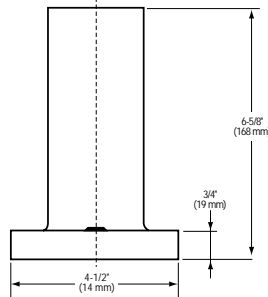



NOSE MOUNTING WITH A PORTABLE LOCK BUSHING
Bant-A-Matic and Par-A-Matic Drills

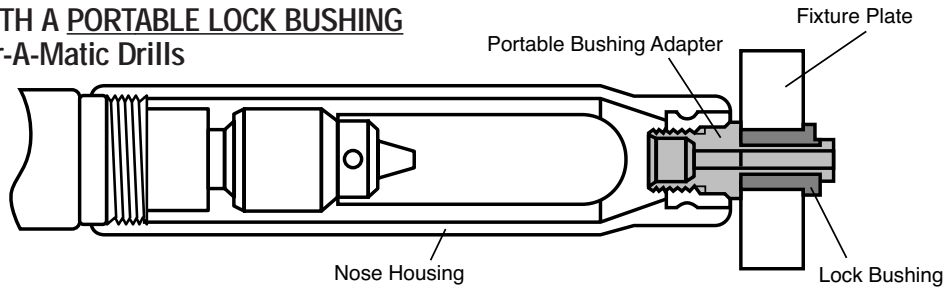

NOSE MOUNTING WITH A PORTABLE LOCK BUSHING
Super Par-A-Matic and Hi-Thrust Drills

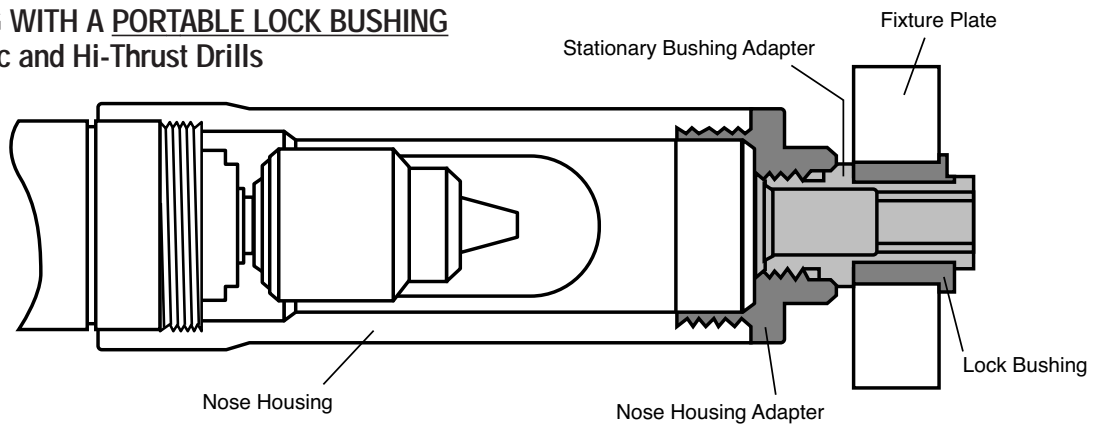

NOSE MOUNTING WITH A STATIONARY LOCK BUSHING
Bant-A-Matic and Par-A-Matic Drills

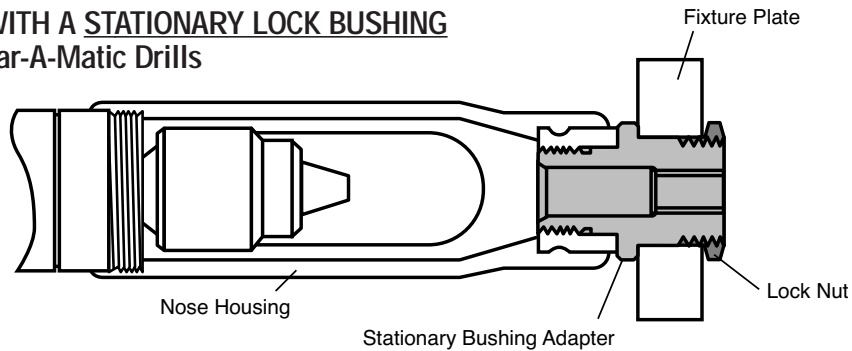

NOSE MOUNTING WITH A STATIONARY LOCK BUSHING
Super Par-A-Matic and Hi-Thrust Drills

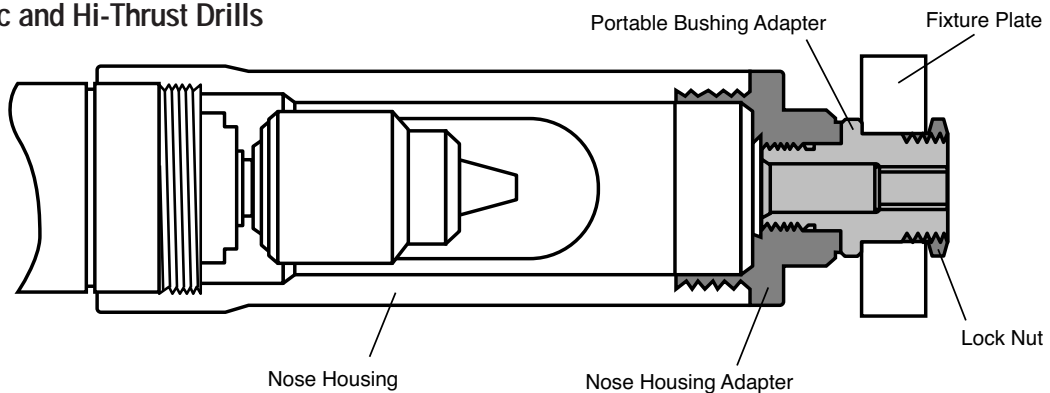

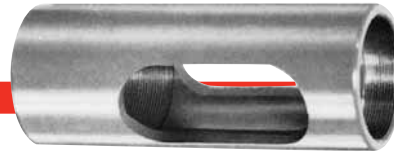
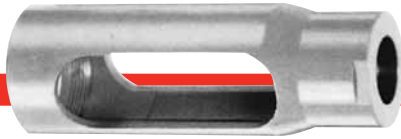

Fig. 1

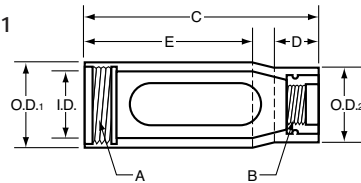
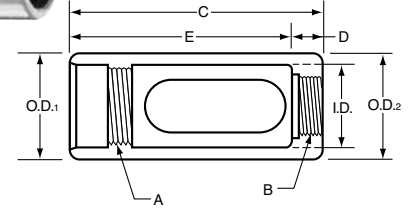

Fig. 2



NOSE HOUSINGS

DRILL MODEL	NOSE HOUSING	THREAD SIZES		LENGTH C in. (mm)	O.D. ₁ in. (mm)	DIAMETERS				
		A To tool	B To bushings/adaptor			O.D. ₂ in. (mm)	I.D. in. (mm)	D in. (mm)	E in. (mm)	
Bant-A-Matic Drills (figure 1)										
8245/8345-202-1 & 2	35918	1-7/16"-18	3/4"-16	5.7	1.6	1.4	1.3	1.0	4.2	
8245/8345-B45-1 & 2		UNEF-2B L.H.	UNF-2B L.H.	(145)	(41)	(36)	(33)	(25)	(107)	
8245/8345-B30-1 & 2										
8245/8345-B8-1 & 2										
8245/8345-101-1 & 2										
8245/8345-202-3										
8245/8345-101-3	35917	1-7/16"-18	3/4"-16	6.4	1.6	1.4	1.3	1.1	4.8	
8245/8345-B45-3		UNEF-2B L.H.	UNF-2B L.H.	(163)	(41)	(36)	(33)	(28)	(122)	
8245/8345-B30-3										
8245/8345-B8-3	40804	1-7/16"-18	3/4"-16	7.5	1.6	1.4	1.3	1.1	6.0	
		UNEF-2B L.H.	UNF-2B L.H.	(191)	(41)	(36)	(33)	(28)	(152)	
Par-A-Matic Drills* (figure 1)										
8255/8355-171-1 & 2	35722	2"-16 UN-2B L.H. 3/4"-16 UNF-2B L.H.								
8255/8355-A50-1 & 2	or			4.75	2.2	1.9	1.75	1.1	3.0	
8255/8355-A28-1 & 2	35720	2"-16 UN-2B L.H.	1"-14 UNF-2B L.H.	(121)	(56)	(48)	(44)	(28)	(76)	
8255/8355-A21-1 & 2	or									
	36495	2"-16 UN-2B L.H.	1-1/4"-12 UNF-2B L.H.							
8255/8355-A14-1 & 2										
8255/8355-101-1 & 2										
8255/8355-A8-1 & 2	38852	2"-16 UN-2B L.H.	3/4"-16 UNF-2B L.H.							
8255/8355-A5-1 & 2	or									
8255/8355-171-3	38853	2"-16 UN-2B L.H.	1"-14 UNF-2B L.H.	6.1	2.2	1.9	1.75	1.1	4.4	
8255/8355-101-3	or			(155)	(56)	(48)	(44)	(28)	(112)	
8255/8355-A50-3	38854	2"-16 UN-2B L.H.	1-1/4"-12 UNF-2B L.H.							
8255/8355-A28-3										
8255/8355-A21-3										
	40810	2"-16 UN-2B L.H.	3/4"-16 UNF-2B L.H.							
8255/8355-A14-3	or			7.25	2.2	1.9	1.75	1.1	5.5	
8255/8355-A8-3	40811	2"-16 UN-2B L.H.	1"-14 UNF-2B L.H.	(184)	(56)	(48)	(44)	(28)	(140)	
8255/8355-A5-3	or									
	40812	2"-16 UN-2B L.H.	1-1/4"-12 UNF-2B L.H.							
Super Par-A-Matic Drills (figure 2)										
8265-170-1 & 3										
8265-46-1 & 3	40584-1	2-1/2"-16	2-3/8"-16	6.0	2.9	2.7	2.0	0.88	3.9	
8265-25-1 & 3		UN-2B L.H.	UN-2B L.H.	(152)	(74)	(69)	(51)	(22)	(99)	
8265-12-1 & 3										
8265101-1 & 3	40584-2	2-1/2"-16	2-3/8"-16	7.8	2.9	2.7	2.0	0.88	5.7	
8265-6-1 & 3		UN-2B L.H.	UN-2B L.H.	(198)	(74)	(69)	(51)	(22)	(145)	
8265-3-1 & 3										
Hi-Thrust Drills (figure 2)										
8670-(-)-3	45188	2-7/8"-16	2-3/8"-16	9.8	3.6	3.6	2.9	1.0	6.1	
		UN-2B L.H.	UN-2B L.H.	(249)	(92)	(92)	(74)	(25)	(155)	

*Nose housing used will depend upon the size of the Portable or Stationary Bushing Adapter needed.

NOTE: Nose housing with bushing adapter may be used as a drill guide in conjunction with either a Collet-type Foot Bracket or a Block Clamp. Use appropriate press-fit drill guide bushing in a Stationary Bushing Adapter or Portable Bushing Adapter.

Nose Housings of significant weight: 44971-1 = 1.0 lbs. (.45 kg), 44971-2 = 1.5 lbs. (.68 kg), 45188 = 7.5 lbs. (3.4 kg).

NOSE HOUSING ADAPTERS*

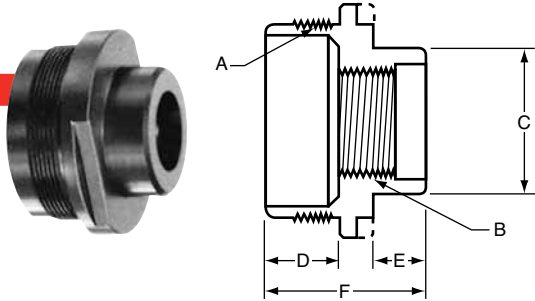

NOSE HOUSING ADAPTER	THREAD SIZES					
	A To nose housing	B To stationary/portable bushing	C in. (mm)	D in. (mm)	E in. (mm)	F in. (mm)
33812		3/4"-16 UNF-2B L.H.	1.75 (44)			
33751		1"-14 UNF-2B L.H.	1.75 (44)	1.0	0.625	1.875
33764	2-3/8"-16 UN-2A L.H.	1-1/4"-12 UNF-2B L.H.	1.75 (44)	(25.4)	(16)	(47)
34075		1-1/2"-12 UNF-2B L.H.	2.0 (51)			
46695		2"-16 UN-2B L.H.	2.75 (69)			

*Use with nose mounting for Super Par-A-Matic and Hi-Thrust Drills. (See Page 47)

STATIONARY LOCK BUSHINGS

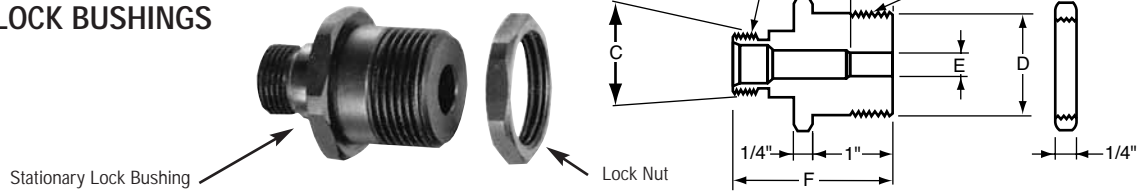

DRILL DIA. RANGE INCHES	STATIONARY LOCK BUSHING ADAPTER, PART NO.	LOCK NUT PART NO.	"A" THREAD SIZE (TO NOSE HOUSING)	"B" MOUNTING THREAD	"C" PILOT DIA. INCHES (+.0000, -.0005)	"D" MOUNT PILOT DIA., INCHES (+.000, -.002)	"E" PRESS FIT DIA., FOR HEADLESS PRESS FIT DRILL BUSHING, INCHES (+.0005, -.0000)	"F" LENGTH OF STATIONARY LOCK BUSHING ADAPTER, INCHES
.0135-.0995	36646	38850 (1-1/2 HEX)	3/4"-16 UNF-2A, L.H.	1-1/4"-12 UNF-2A	.8115	1.248	.2036	2.000
.0980-.1406	36647	38850 (1-1/2 HEX)	3/4"-16 UNF-2A, L.H.	1-1/4"-12 UNF-2A	.8115	1.248	.2506	2.000
.1250-.1935	36648	38850 (1-1/2 HEX)	3/4"-16 UNF-2A, L.H.	1-1/4"-12 UNF-2A	.8115	1.248	.3131	2.000
.1875-.3160	36649	38850 (1-1/2 HEX)	3/4"-16 UNF-2A, L.H.	1-1/4"-12 UNF-2A	.8115	1.248	.5007	2.000
.1875-.3160	36650	38850 (1-1/2 HEX)	1"-14 UNF-2A, L.H.	1-1/4"-12 UNF-2A	1.0615	1.248	.5007	2.187
.3125-.5312	36651	38850 (1-1/2 HEX)	1-1/4"-12 UNF-2A, L.H.	1-1/4"-12 UNF-2A	1.3115	1.248	.7508	2.187
.5000-.7656	46088	46089 (1-5/8 HEX)	1-1/2"-12 UNF-2A, L.H.	1-1/2"-12 UNF-2A	1.5710	1.498	1.0008	2.187

NOTE: Stationary Lock Bushing and Lock Nut must be ordered separately.

PORTABLE LOCK BUSHINGS

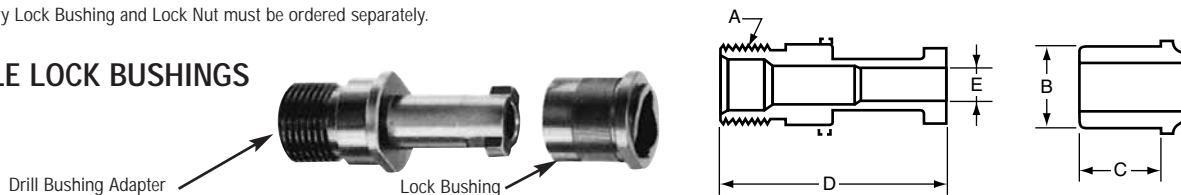

DRILL DIA. RANGE INCHES	PORTABLE DRILL BUSHING ADAPTER, PART NO.	LOCK BUSHING PART NO.	"A" THREAD SIZE (TO NOSE HOUSING)	"B" LOCK BUSHING PRESS FIT DIA., INCHES, +.000, -.001	"C" LENGTH OF PRESS FIT DIA. B, INCHES	"D" LENGTH OF PORTABLE DRILL BUSHING, INCHES	"E" PRESS FIT DIA. FOR HEADLESS PRESS FIT DRILL BUSHING, IN., +.0005, -.0000
.0135-.0995	35214	35215	3/4"-16 UNF-2A, L.H.	0.686	0.750	2.172	0.2036
.0980-.1406	35216	35217	3/4"-16 UNF-2A, L.H.	0.749	0.750	2.172	0.2506
.1250-.1935	35218-1	35219	3/4"-16 UNF-2A, L.H.	0.811	0.750	2.172	0.3131
.1875-.3160	35220	35221-1	1"-14 UNF-2A, L.H.	0.999	0.750	2.203	0.5007
.3125-.5312	35222-1	35223	1-1/4"-12 UNF-2A, L.H.	1.374	1.000	2.516	0.7508
.5000-.7656	35224	35225	1-1/2"-12 UNF-2A, L.H.	1.749	1.125	2.656	1.0008

NOTE: Portable Drill Bushing and Lock Bushing must be ordered separately.

Dimensional CAD downloads are available in a variety of formats. 2D and 3D DXF, IGS, AUTOCAD R12 and AUTOCAD R13 are a few examples. Visit the following websites to download your format of choice.

www.irtools.com
(Drilling-Fixtured Downloads)

or

www.arozone.com
(Literature-Automatic Machining Tools)

Dimensional Data



SERIES 34A, 54C & 74B ELECTRA-FEED DRILLS

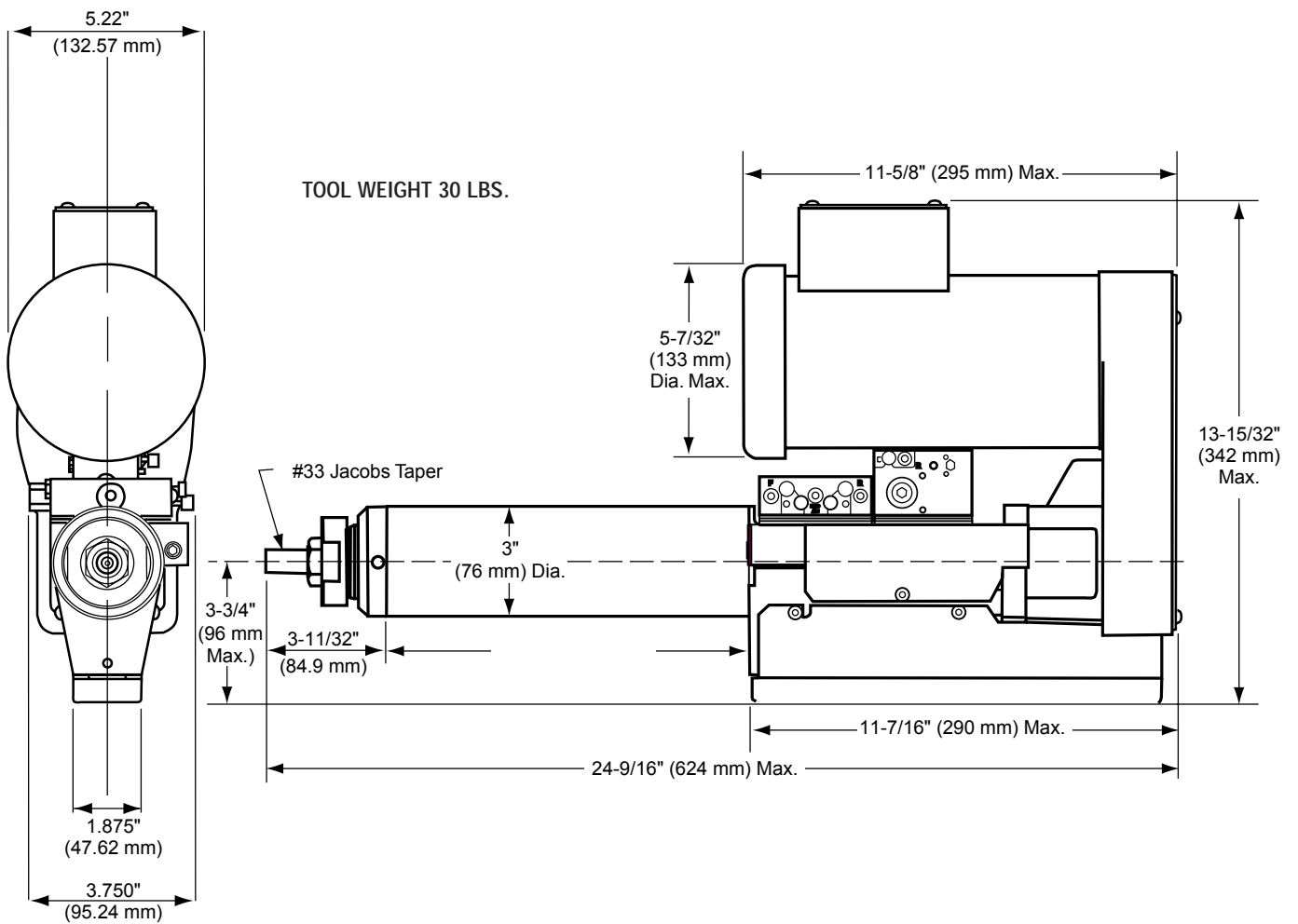

BANT-A-MATIC DRILLS
8245-B(-)-1 AND 8345-B(-)-1

TOOL WEIGHT 4.2 LBS.

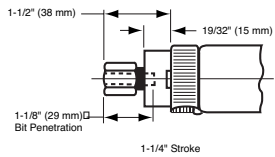

Shows built-in-collet used on 19,000 RPM Tools.

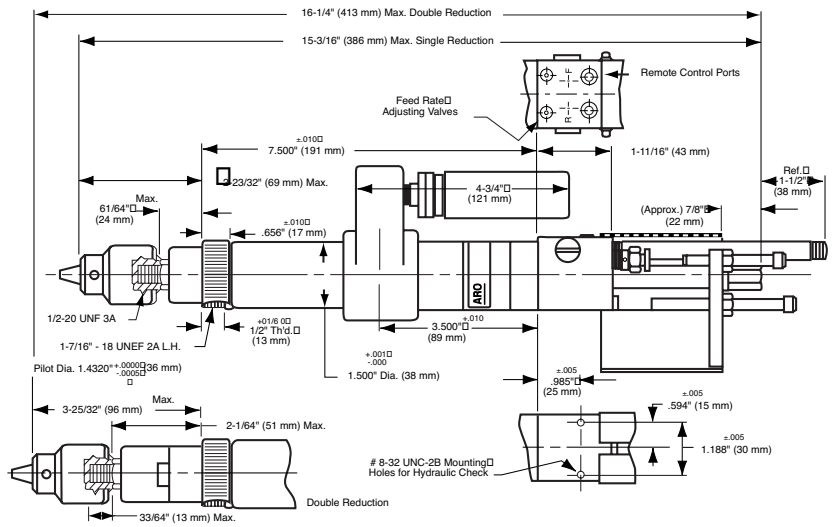

BANT-A-MATIC DRILLS
8245-B(-)-2 AND 8345-B(-)-2

TOOL WEIGHT 4.8 LBS.

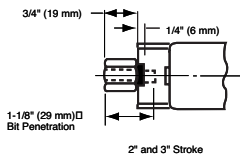

Shows built-in-collet used on 19,000 RPM Tools.

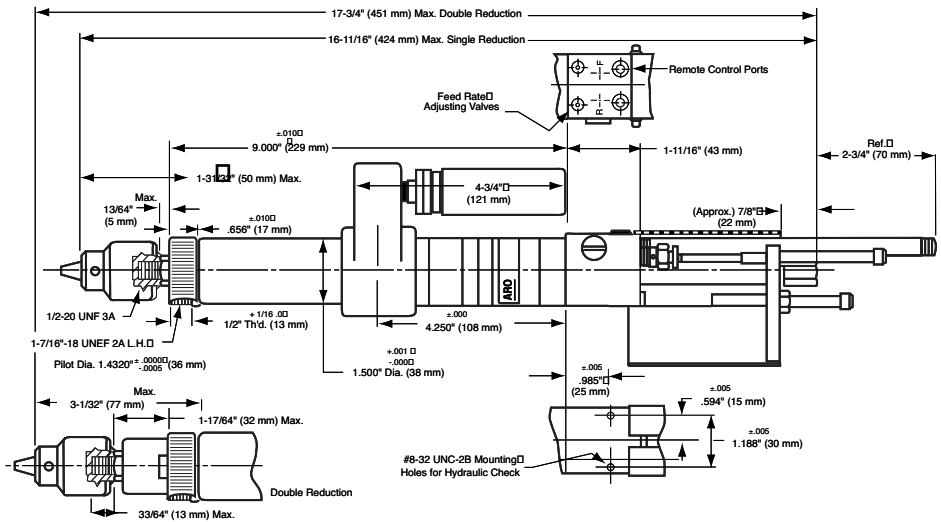

BANT-A-MATIC DRILLS
8245-B(-)-3 AND 8345-B(-)-3

TOOL WEIGHT 5.8 LBS.

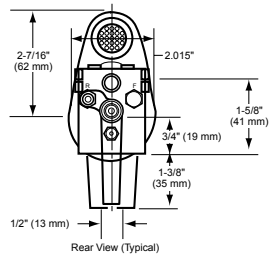

Rear View (Typical)

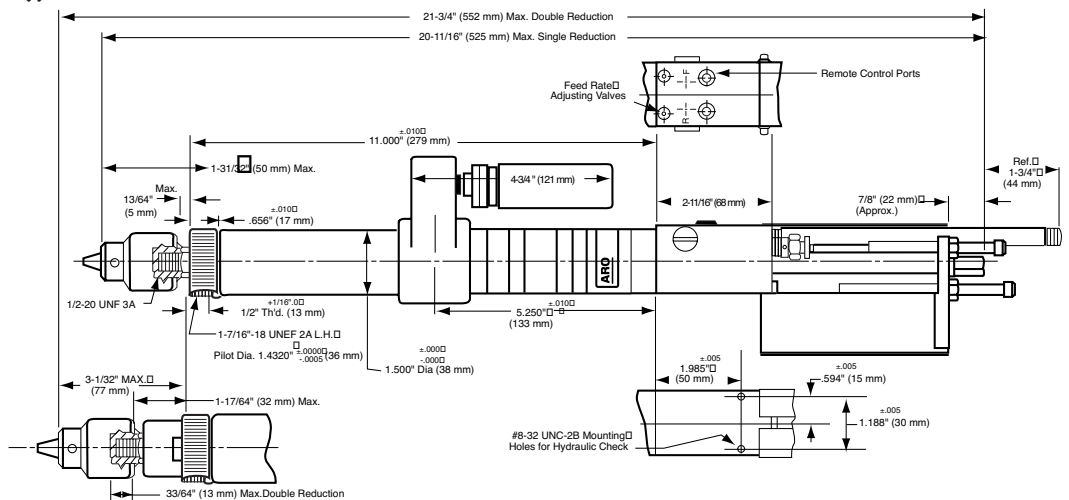

Dimensional Data



BANT-A-MATIC TWIN DRILLS 8248-B(-)1

TOOL WEIGHT 5.7 LBS.

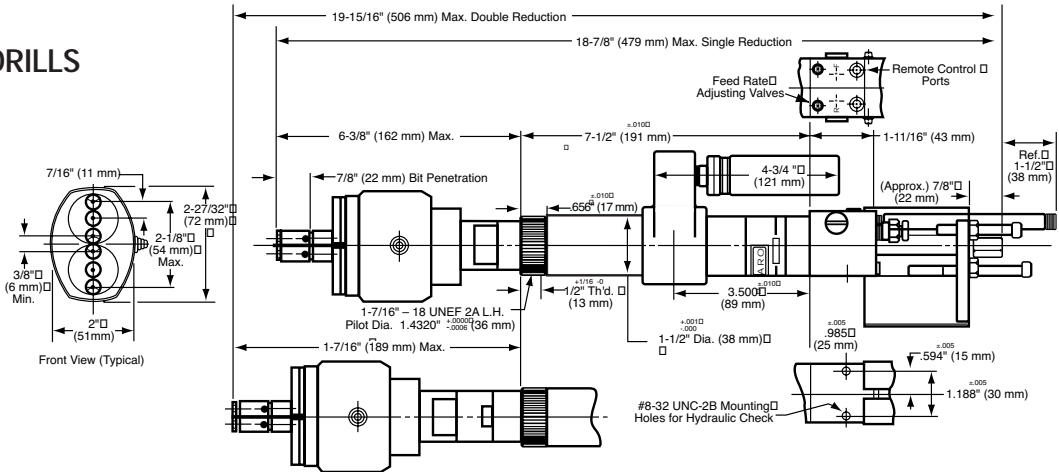

BANT-A-MATIC TWIN DRILLS 8248-B(-)2

TOOL WEIGHT 6.3 LBS.

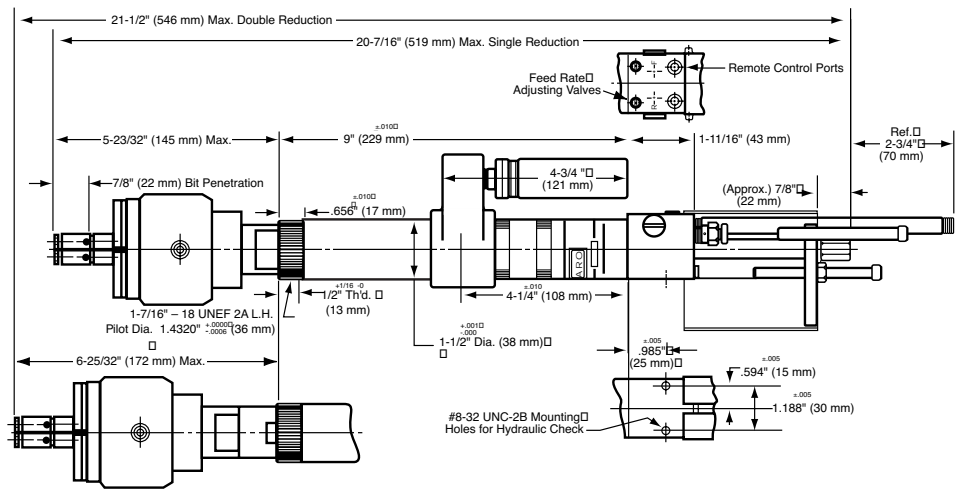

BANT-A-MATIC TWIN DRILLS 8248-B(-)3

TOOL WEIGHT 7.3 LBS.

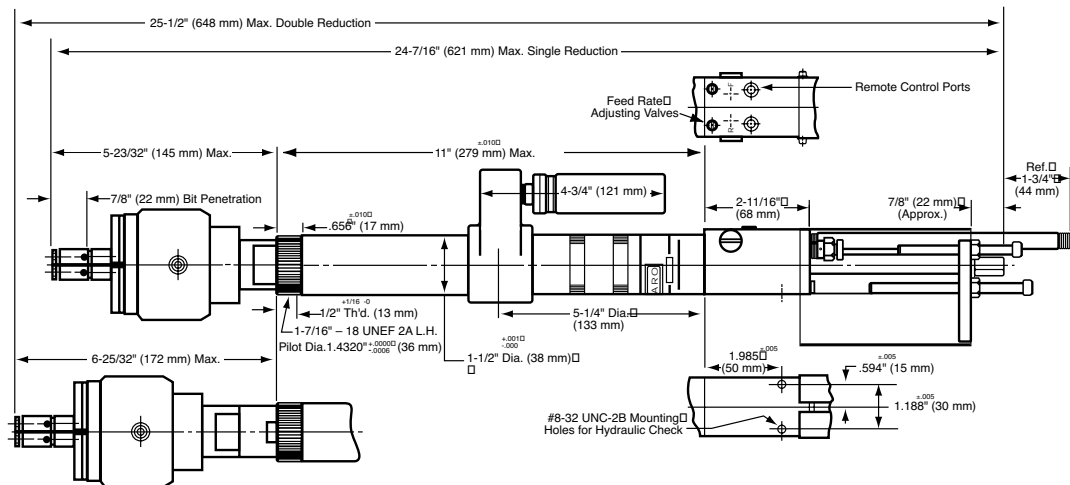

Dimensional Data



**PAR-A-MATIC DRILLS
8255-A(-)-1 AND 8355-A(-)-1**

Shows built-in-collet used on 17,000 RPM Tools.

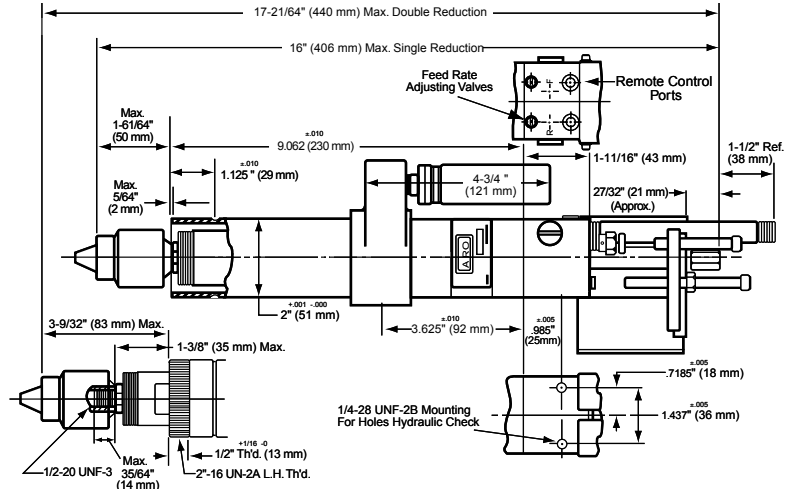
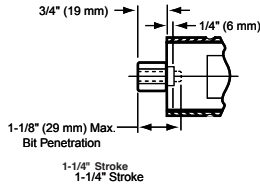

**PAR-A-MATIC DRILLS
8255-A(-)-2 AND 8355-A(-)-2**

TOOL WEIGHT 8.0 LBS.

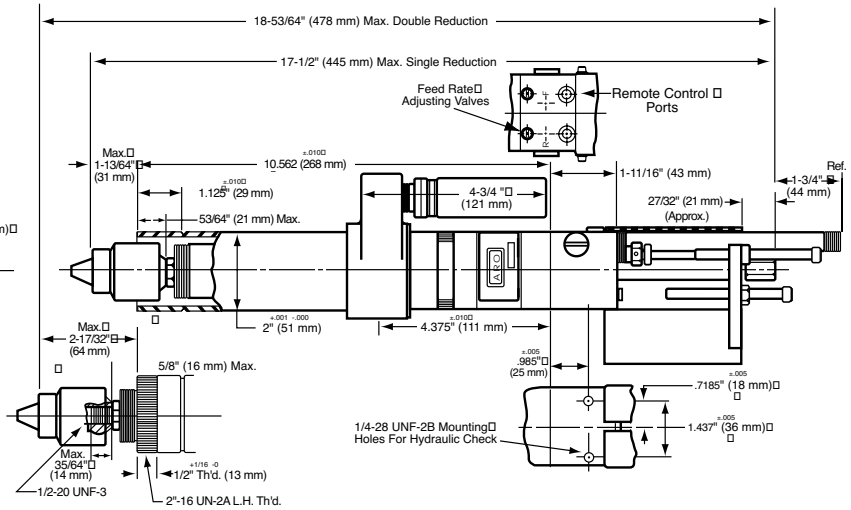
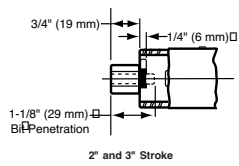

**PAR-A-MATIC DRILLS
8255-A(-)-3 AND 8355-A(-)-3**

TOOL WEIGHT 9.5 LBS.

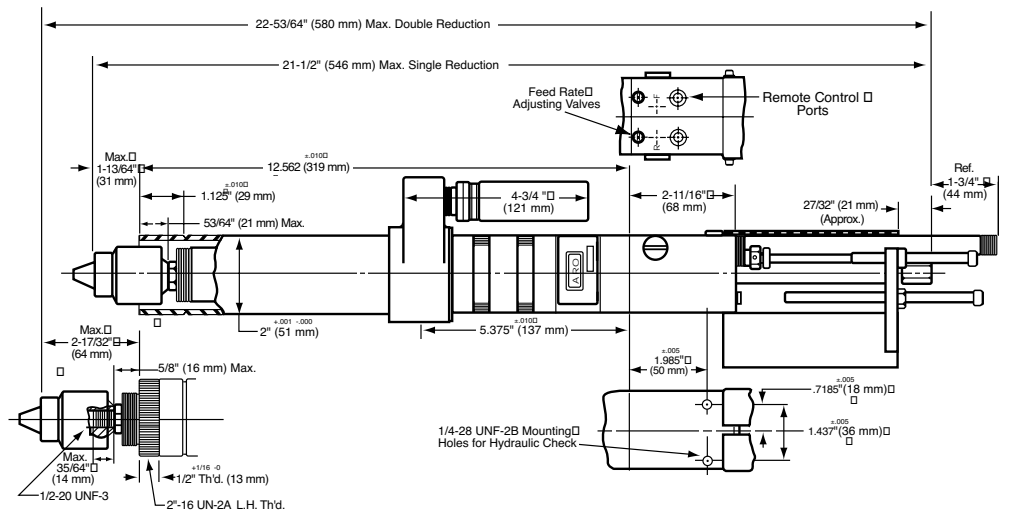
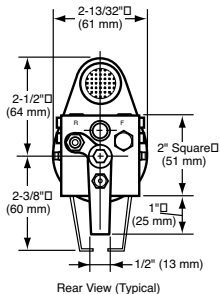

Dimensional Data



PAR-A-MATIC TWIN DRILLS 8258-C(-)1

TOOL WEIGHT 9.6 LBS.

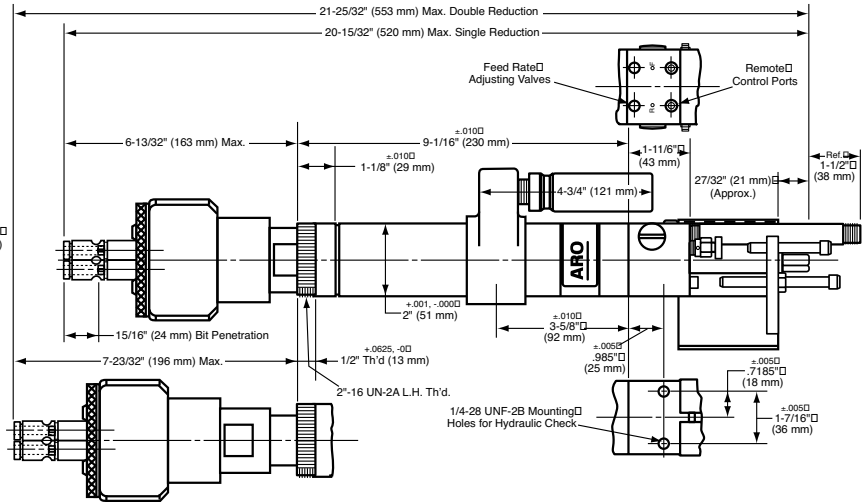
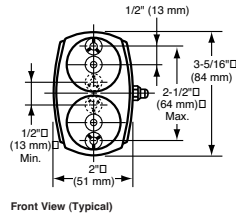

PAR-A-MATIC TWIN DRILLS 8258-C(-)2

TOOL WEIGHT 10.1 LBS.

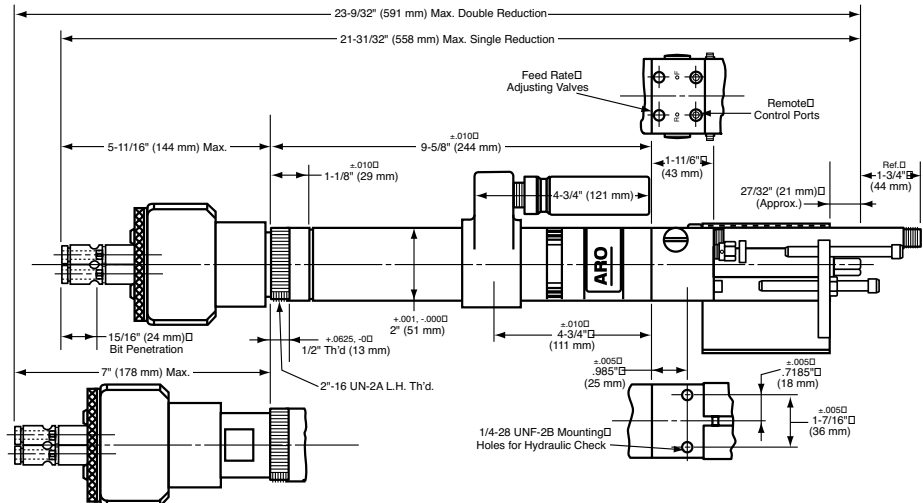

PAR-A-MATIC TWIN DRILLS 8258-C(-)3

TOOL WEIGHT 11.6 LBS.

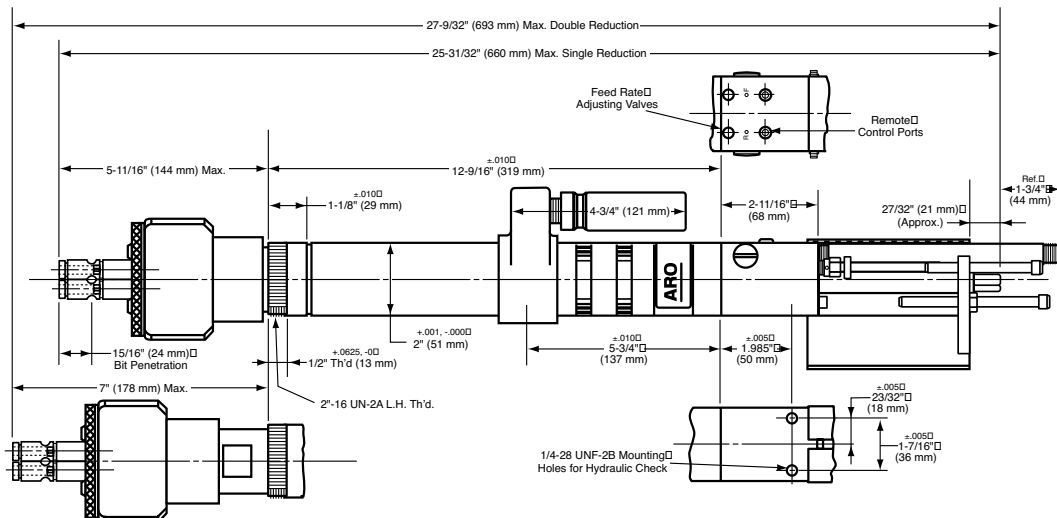

**SUPER PAR-A-MATIC DRILLS
8265(-)-1**

TOOL WEIGHT 13 LBS.

Shows built-in-collet used on
17,000 RPM Tools.

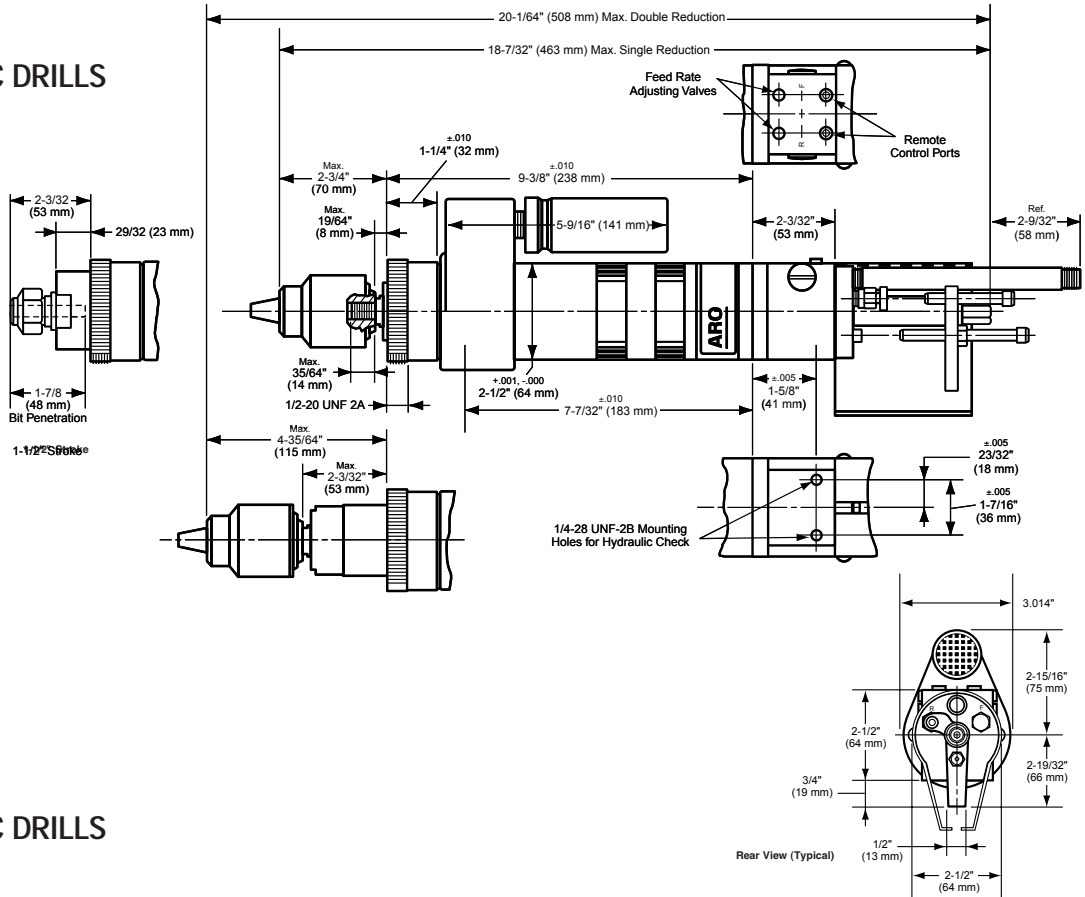

**SUPER PAR-A-MATIC DRILLS
8265(-)-3**

TOOL WEIGHT 14 LBS.

Shows built-in-collet used on
17,000 RPM Tools.

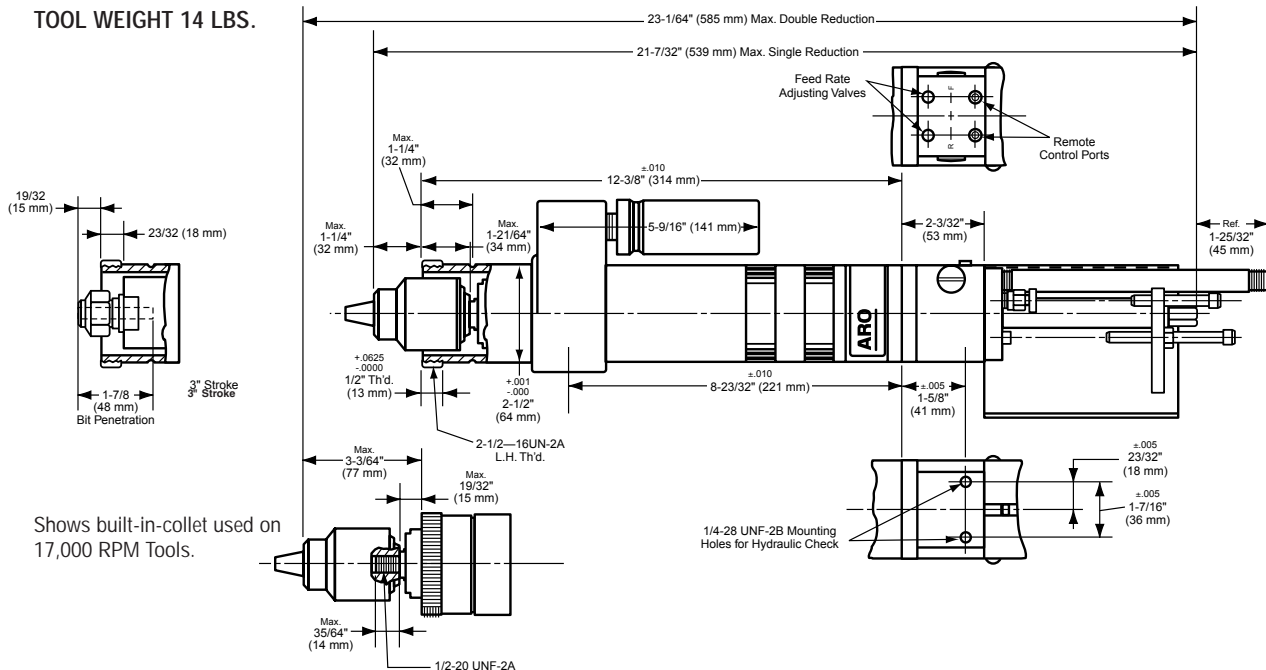

Dimensional Data



SUPER PAR-A-MATIC TWIN DRILLS 8268-A(-)1

TOOL WEIGHT 18.5 LBS.

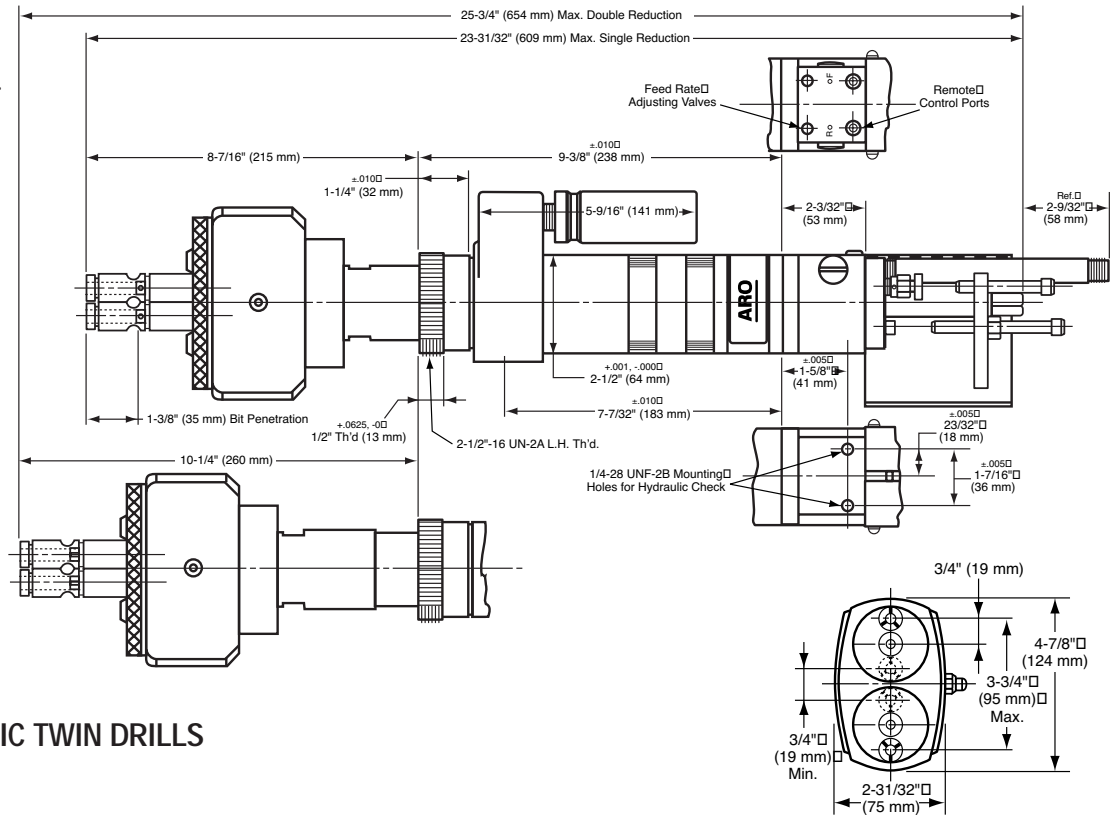

SUPER PAR-A-MATIC TWIN DRILLS 8268-A(-)3

TOOL WEIGHT 19.5 LBS.

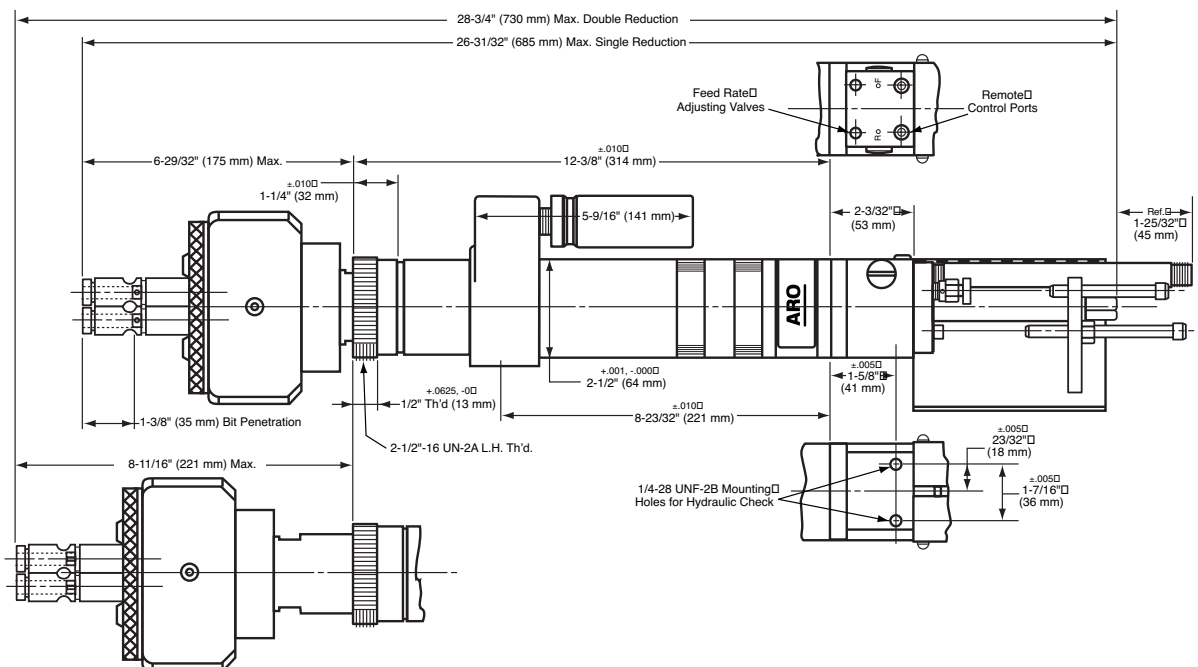

HI-THRUST DRILLS
8670(-)-3

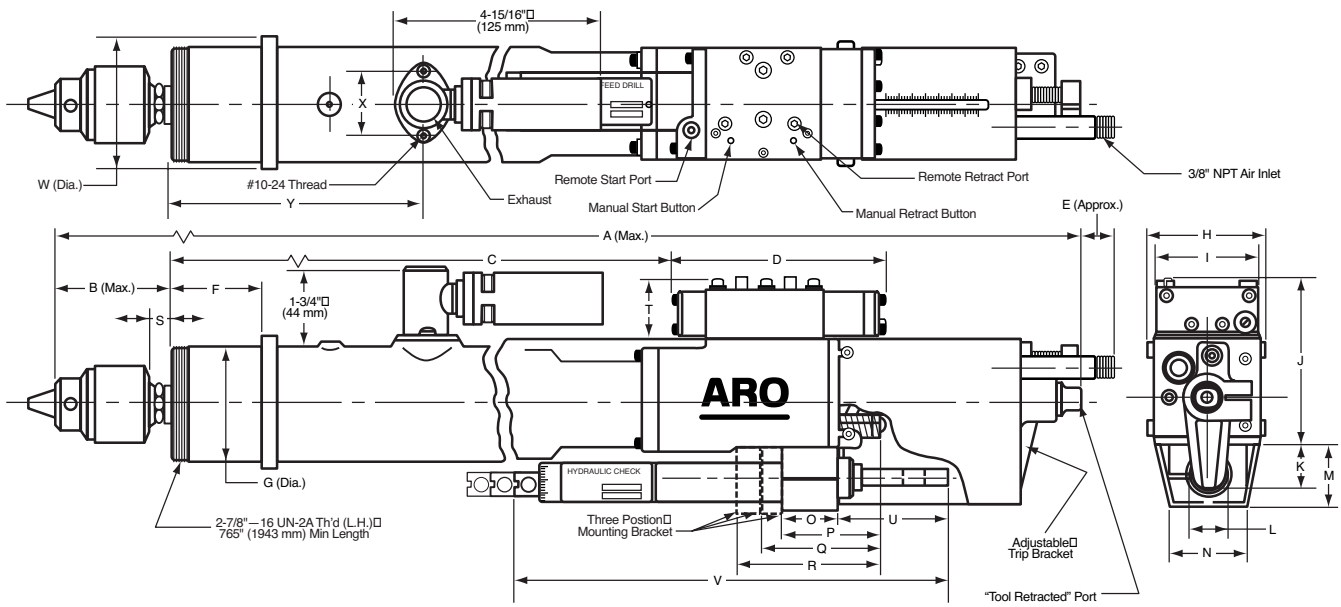

8670 Specifications

A		B	C	D	E			H	I	J	K	L				
3" Stroke					3" Stroke											
in.	27-3/4	3-21/32	14	5-5/16	1-1/16	2.24-2.26	2.872-2.874	2.784	2.5	4.312	61/64	.75				
mm	705	93	355	135	27	56.9-57.4	72.95-73.0	70	64	110	24	19				
M	N	O	P	Q	R	S	T	Hydraulic Check			W	X	Y			
								U			V					
								1" Stroke	2" Stroke	3" Stroke	1" Stroke	2" Stroke	3" Stroke			
1.5	2.0	1.25	2.375	2.937	3.5	15/32	1.5	1.937	2.937	3.937	7.875	10.875	13.875	3.25	1.562	6.344
38	51	32	60	75	89	12	38	49	75	100	200	276	352	83	40	161

Dimensional Data



PAR-A-MATIC PECK DRILLS 8360-()-3

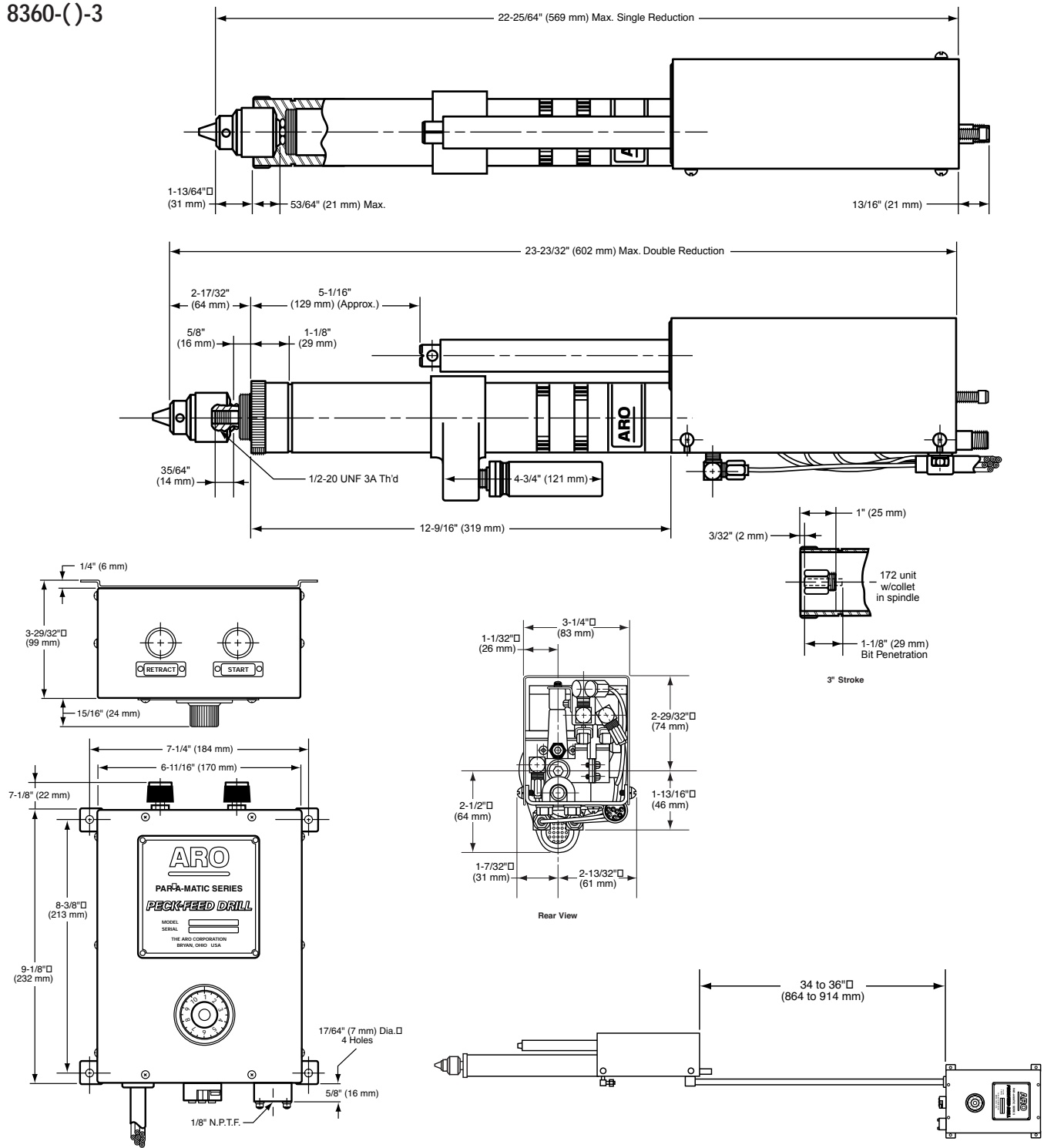

Dimensional Data

DOBCO
EQUIPMENT LTD

PAR-A-MATIC OFFSET DRILLS 8266-A(-)-2

TOOL WEIGHT 8.6 LBS.

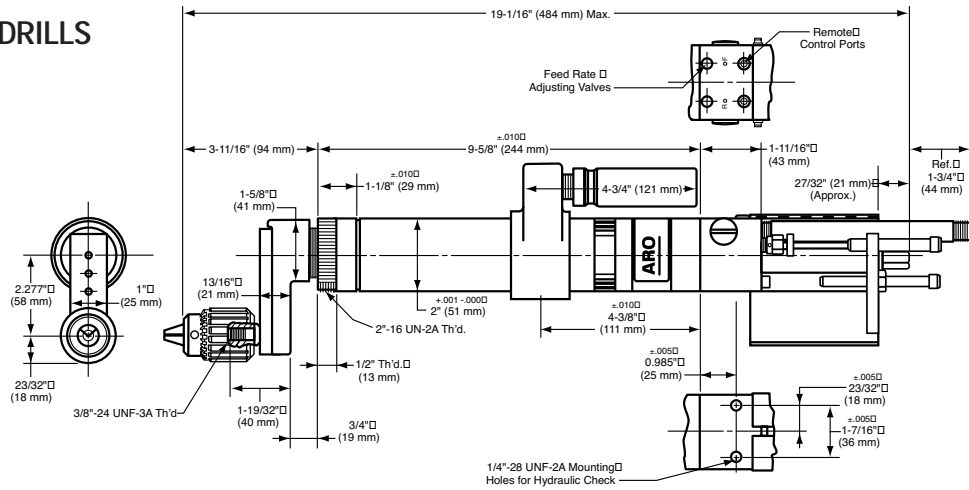

LEAD SCREW TAPPERS 8655-B THRU 8659-B

TOOL WEIGHT 17 LBS.

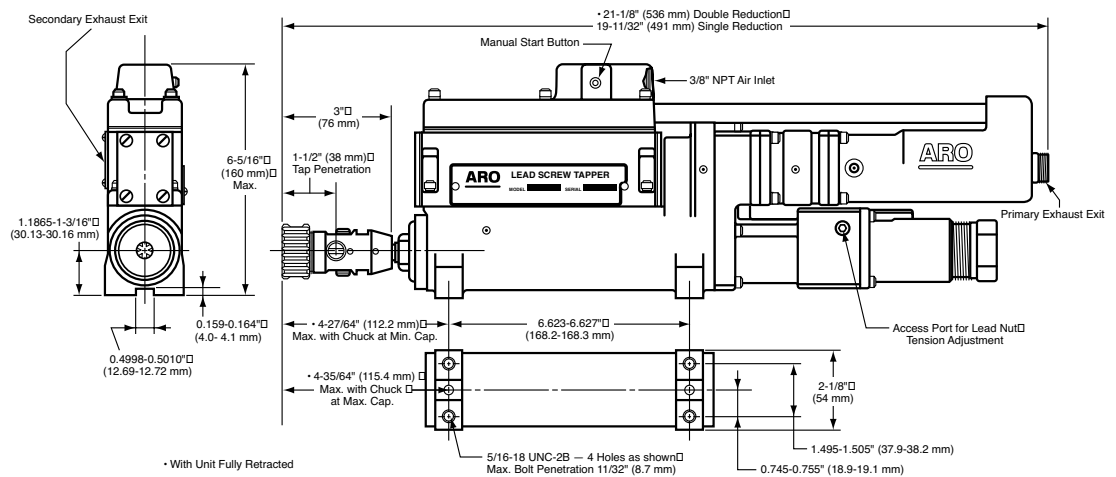

Dimensional Data



BANT-A-MATIC TAPPERS 8246-D(-)-2

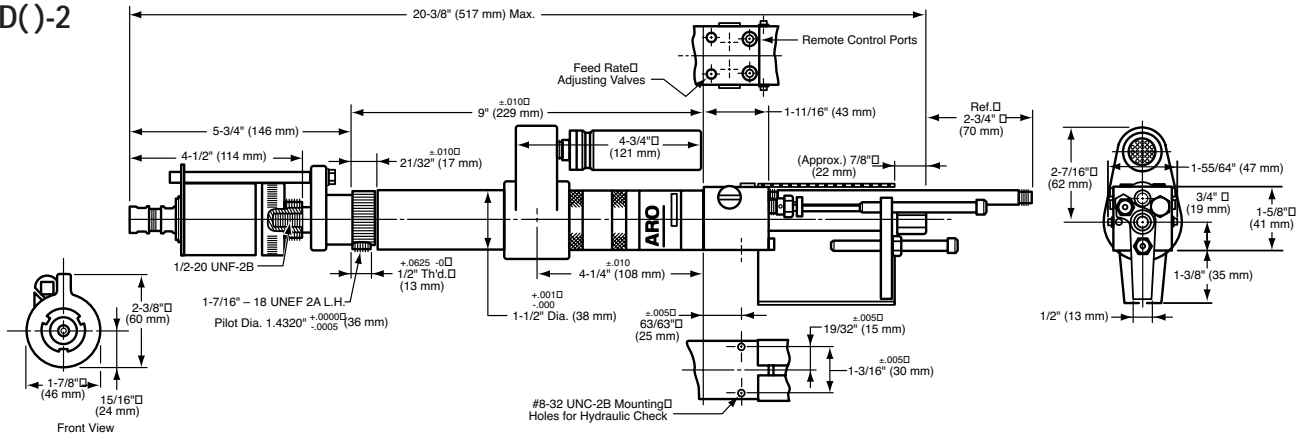

PAR-A-MATIC TAPPERS 8256-C(-)-2

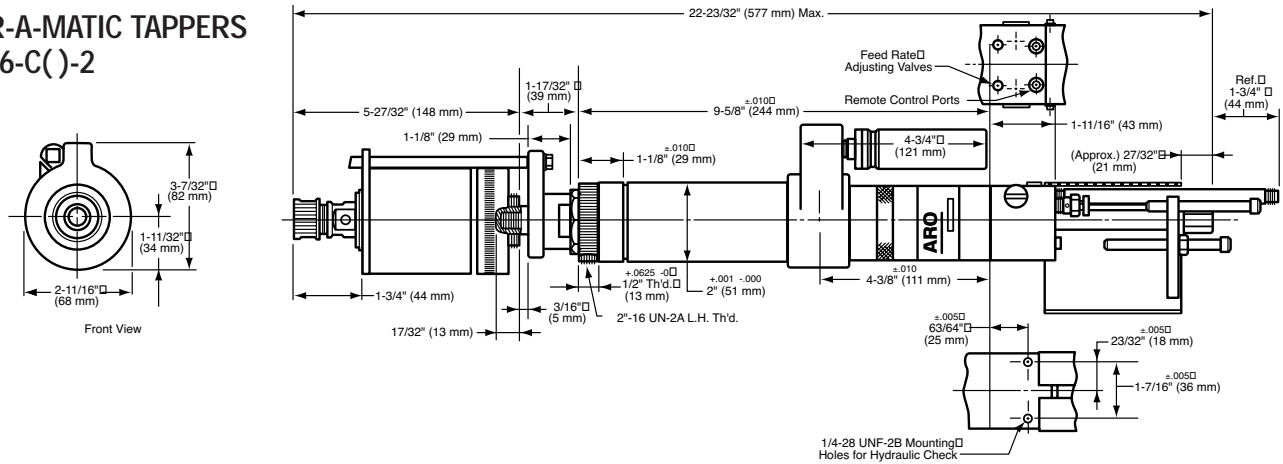

PAR-A-MATIC TAPPERS 8257-A(-)-()

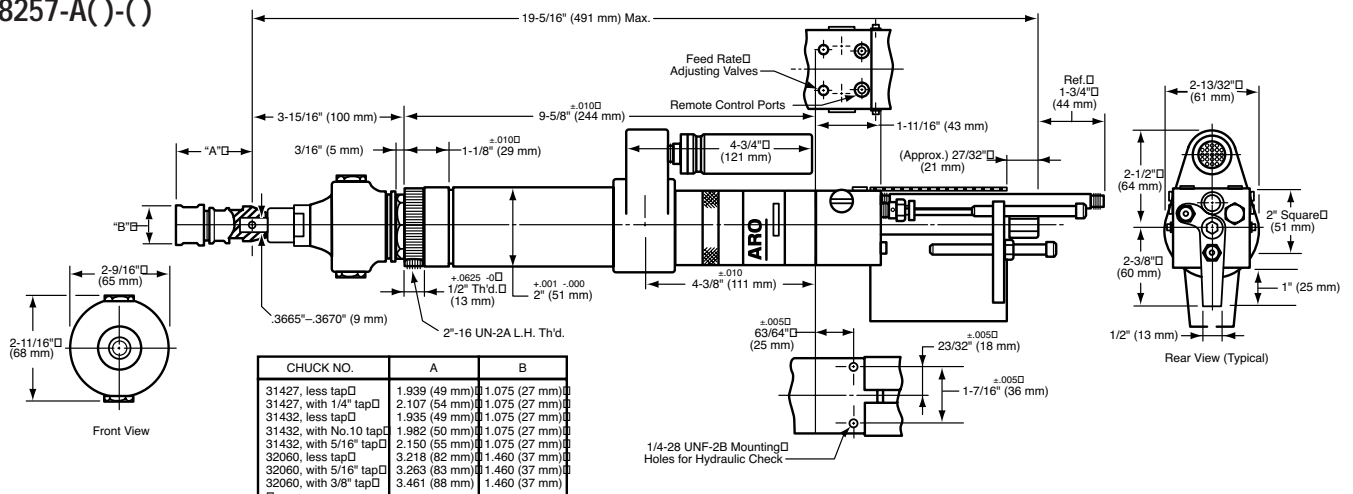



ARO Service Kits are a convenient and economical way to perform in-house preventative maintenance and minimize tool repair down-time. Service Kits are available for nearly all model ARO Automatic Machining Tools. Each kit contains all of the replacement parts needed to properly perform preventative maintenance on a tool to keep it operating "like new". They also serve as an easy method to manage and organize spare parts inventory.

Each part in the service kit is individually wrapped and identified, and packaged in an easy-to-store clearly labeled box. The appropriate tool service manual, parts list, spindle oil and grease are also included.



ORDER INFORMATION

BANT-A-MATIC SERIES

MODELS	DESCRIPTION	KIT NUMBER
8245-B8, 8245-B45 & 8245-202	Drills	
8246-D8	Tapper	
8345-B8, 8345-B45 & 8345-202	Drills	41205-1
8248-B8 & 8248-B45	Twin Drills	
8245-B30 & 8245-101	Drills	
8246-D5	Tapper	
8345-B30 & 8345-101	Drills	41310-1
8248-B30	Twin Drill	

PAR-A-MATIC SERIES

MODELS	DESCRIPTION	KIT NUMBER
All 8255-A	Drills	
All 8256-C	Tappers	
All 8257-A	Tappers	
All 8258-C	Twin Drills	
All 8266-A	Offset Drills	41325
All 8355-A	Drills	
All 8360-A	Peck Drills	

SUPER PAR-A-MATIC SERIES

MODELS	DESCRIPTION	KIT NUMBER
All 8265	Drills	
All 8268-A	Twin Drills	41327

HI-THRUST SERIES

MODELS	DESCRIPTION	KIT NUMBER
All 8660	Drills	45831
All 8670	Drills	45832

LEAD SCREW TAPPERS

MODELS	DESCRIPTION	KIT NUMBER
All 8655-B	Tappers	
All 8656-B	Tappers	
All 8657-B	Tappers	45782
All 8658-B	Tappers	
All 8659-B	Tappers	

Series 34A, 54C & 74B

MODELS	DESCRIPTION	KIT NUMBER
49594	Kit for Main Frame	
49595	Kit for Manifold Assembly	
49596	Kit for Control Assembly	

Refer to operator's manual for service kits of older model tools not herein listed.



COLLET SELECTION FOR HIGH SPEED DRILL UNITS

Collets, built into the spindle, are furnished as standard equipment on all highest speed feed tools. This provides for superior gripping, better balance and lower runout of smaller cutters typically used at these high speeds.

FOR BANT-A-MATIC AND PAR-A-MATIC TOOLS

Models: 8245-203-(), 8255-172-(), 8360-172-3, 8345-203-() and 8355-172-().

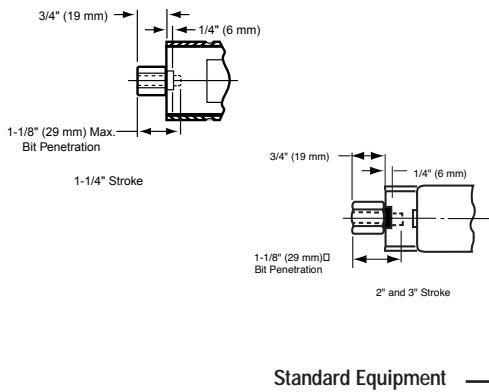

COLLET INSERT NO.	NOMINAL SIZE	MINIMUM CAPACITY		MAXIMUM CAPACITY	
		INCHES	MM	INCHES	MM
31812-1	3/64	1/64	0.40	3/64	1.19
31812-2	5/64	3/64	1.19	5/64	1.98
31812-3	3/32	1/16	1.59	3/32	2.38
31812-4	1/8	3/32	2.38	1/8	3.18
31812-5	5/32	1/8	3.18	5/32	3.97
31812-6	3/16	5/32	3.97	3/16	4.76
31812-7	7/32	3/16	4.76	7.32	5.56
31812-8	1/4	7/32	5.56	1/4	6.35

Order other available collet sizes shown above as, less 31812-8 with 31812-().

FOR SUPER PAR-A-MATIC TOOLS

Models: 8265-171-().

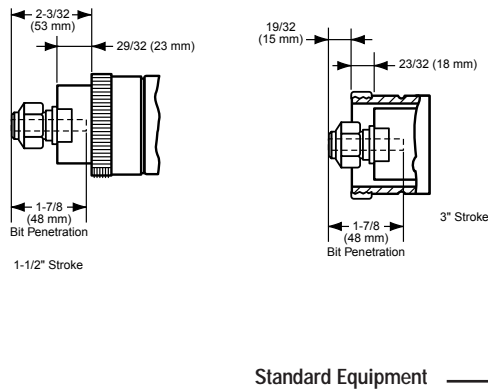

COLLET INSERT NO.	NOMINAL SIZE	MINIMUM CAPACITY		MAXIMUM CAPACITY	
		INCHES	MM	INCHES	MM
32968-1	1/8	1/64	0.40	3/64	1.19
32968-2	5/32	3/64	1.19	5/64	1.98
32968-3	3/16	1/16	1.59	3/32	2.38
32968-4	7/32	3/32	2.38	1/8	3.18
32968-5	1/4	1/8	3.18	5/32	3.97
32968-6	9/32	5/32	3.97	3/16	4.76
32968-7	5/16	3/16	4.76	7.32	5.56
32968-8	11/32	7/32	5.56	1/4	6.35
32968-9	3/8	11/32	8.73	3/8	9.53

Order other available collet sizes shown above as, less 32968-9 with 32968-().

Contact Information



United States

Marketing/Sales/Service Headquarters

Ingersoll-Rand Productivity Solutions
1467 Rte. 31 South
Annandale, NJ 08801

Customer Svc. Center

Ingersoll-Rand Productivity Solutions
510 Hester Drive
White House, TN 37188
Telephone: (615) 672-0321
Fax: (615) 285-0802

Customer Svc. Center

Ingersoll-Rand Productivity Solutions
One ARO Center
Bryan, OH 43506
Telephone: (800) 276-4658
Fax: (800) 266-7016

Sales Office

Ingersoll-Rand Productivity Solutions
1872 Enterprise Drive
Rochester Hills, MI 48309
Telephone: (248) 293-5700
Fax: (248) 293-5807

Sales Office

Ingersoll-Rand Productivity Solutions
1467 Route 31 South
Annandale, NJ 08801
Telephone: (908) 238-7129
Fax: (908) 238-7053

Canada

Marketing/Sales/Service Headquarters

Ingersoll-Rand Canada Inc.
51 Worcester Road
Toronto, Ontario M9W 4K2
Telephone: (416) 213-4500
Fax: (416) 213-4510

Quebec

Ingersoll-Rand Canada Inc.
3501 St. Charles Blvd. Suite 104
Kirkland, Quebec H9H 4S3
Telephone: (514) 695-9040
Fax: (514) 695-0963

Latin America

Marketing/Sales/Service Headquarters

Ingersoll-Rand Company
730 N.W. 107th Ave. Suite 300
Miami, FL 33172-3107
Telephone: (305) 559-0500
Fax: (305) 222-0864

Brasil

Ingersoll-Rand do Brasil Ltda.
Productivity Solutions
Av. Dr. Cardoso de Melo 1855
cj. 152-04548-005 Sao Paulo, SP
Brasil
Telephone: (55) 11 3049-8900
Fax: (55) 11 3846-4985

Mexico

Ingersoll-Rand S.A. de C.V.
Productivity Solutions
Blvd. Centro Industrial #11
Fracc. Industrial Puente de Vigas, 54090
Tlanepilantla, Edo. de Mexico, Mexico
Telephone: (52) 5 565-3061
Fax: (52) 5 565-3072

Europe/Middle East/Africa

Productivity Solutions Headquarters and European Customer Care Centre

Ingersoll-Rand
Zone du Che?ne Sorcier
BP 62
78346 Les Clayes sous Bois Cedex
France
Telephone: +33 (0)1 30 07 68 00
Fax: +33 (0)1 30 07 69 80

Ingersoll-Rand Distribution Centre

Swan Lane
Hindley Green
Wigan
Lancashire WN2 4EZ
England
Phone: +44 (0)1942 257131
Fax: +44 (0)1942 526255

Asia/Pacific

Marketing/Sales/Service Headquarters

Ingersoll-Rand Asia Pacific
23/F., 625 Kings Point Road
North Point
Hong Kong
Phone: (852) 2527 -0183
Fax: (852) 2529 -5976

Australia

Ingersoll-Rand Australia, Ltd.
1 Hartnett Drive
Mail: PMB 2, Carrum Downs BC, Vic., 3201
Seaford, Victoria 3198
Australia
Phone: (61) 3 9554 1600
Fax: (61) 3 9554 1611

India

Ingersoll-Rand Wadco Tools, Ltd.
37A, Site 4
Sahibabad Industrial Area
Ghaziabad 201 010 (UP)
India
Phone: (91) 0120-4771-001-4
Fax: (91) 0120-4771-005



Ontario's Largest
Pneumatic & Hydraulic Tool Distributor

1-2430 Lucknow Drive, Mississauga, Ontario L5S 1V3. Tel: 905-672-5557 Fax: 905-672-5559
Email: sales@dobcoeqp.com www.dobcoeqp.com



ARO Tool Products

Ingersoll-Rand Company
P.O. Box 8000
Southern Pines, NC 28387